

HashMark-Master II™ HP Product Manual

For Use With Newstripe High Pressure Airless Machines



1700 Jasper St., Unit F, Aurora, CO 80011 T 800.624.6706 F 303.364.7796 • Newstripe.com

HashMark-Master II™ HP Manual / 4800.0123

HashMark-Master II™ HP

ALWAYS wear safety goggles or protective eye-wear when operating the unit!

TABLE OF CONTENTS

Precautionary Warning.....Page 1

Parts Breakdown.....Page 2

Assembly & Adjustment.....Page 3-4

Operation.....Page 5

Stowing Procedure.....Page 6

Airless Spray Gun Detail.....Page 7

WarrantyPage 8

Thank you! And congratulations on your purchase of the HashMark-Master II™ HP by Newstripe. You can now precisely and accurately layout hash marks without the use of stencils or templates!

Please read over the instructions and make sure you understand operating procedures before using the unit.



1700 Jasper St., Unit F, Aurora, CO 80011 T 800.624.6706 F 303.364.7796 • Newstripe.com

HashMark-Master II™ HP Manual / 4800.0123

HashMark-Master II™ HP

ALWAYS wear safety goggles or protective eyewear when operating the unit!



PRECAUTIONARY WARNING!

- Please read and understand all operation instructions as detailed in this manual. Failure to follow specified instructions may result in equipment damage or serious injury to personnel, up to and including death!
- **TO BE USED ONLY WITH WATER AND OIL BASED PAINTS.**
- **Skin Injection Hazard:** High Pressure spray can inject toxins into the blood stream. If injection occurs, seek emergency medical treatment immediately.
- **NEVER** try to stop or deflect leaks with any part of your body.
- **ALWAYS** release the pressure in the system before changing or cleaning the spray tip.
- **ALWAYS** use the nozzle tip guard.
- **ALWAYS** engage the **Trigger Lock on the spray gun** before removing the spray gun for hand operation.
- **NEVER** place your hands or any body parts in front of the spray gun.
- **NEVER** point the spray gun at or spray other persons or animals.
- **NEVER** clean the spray tip while it is attached to the spray gun. Remove the spray tip from the gun to clean the tip guard.
- **NEVER** remove the spray tip while cleaning the pump.
- **NEVER** use pliers to tighten or loosen high pressure fittings on the outlet side of pump.
- Use only in a well-ventilated area.
- Always consult your Facility Safety and/or Personnel Department for specified safety protocols prior to operating this equipment.



1700 Jasper St., Unit F, Aurora, CO 80011 T 800.624.6706 F 303.364.7796 • Newstripe.com

HashMark-Master II™ HP Manual / 4800.0123

HashMark-Master II™ HP

ALWAYS wear safety goggles or protective eyewear when operating the unit!

PARTS BREAKDOWN

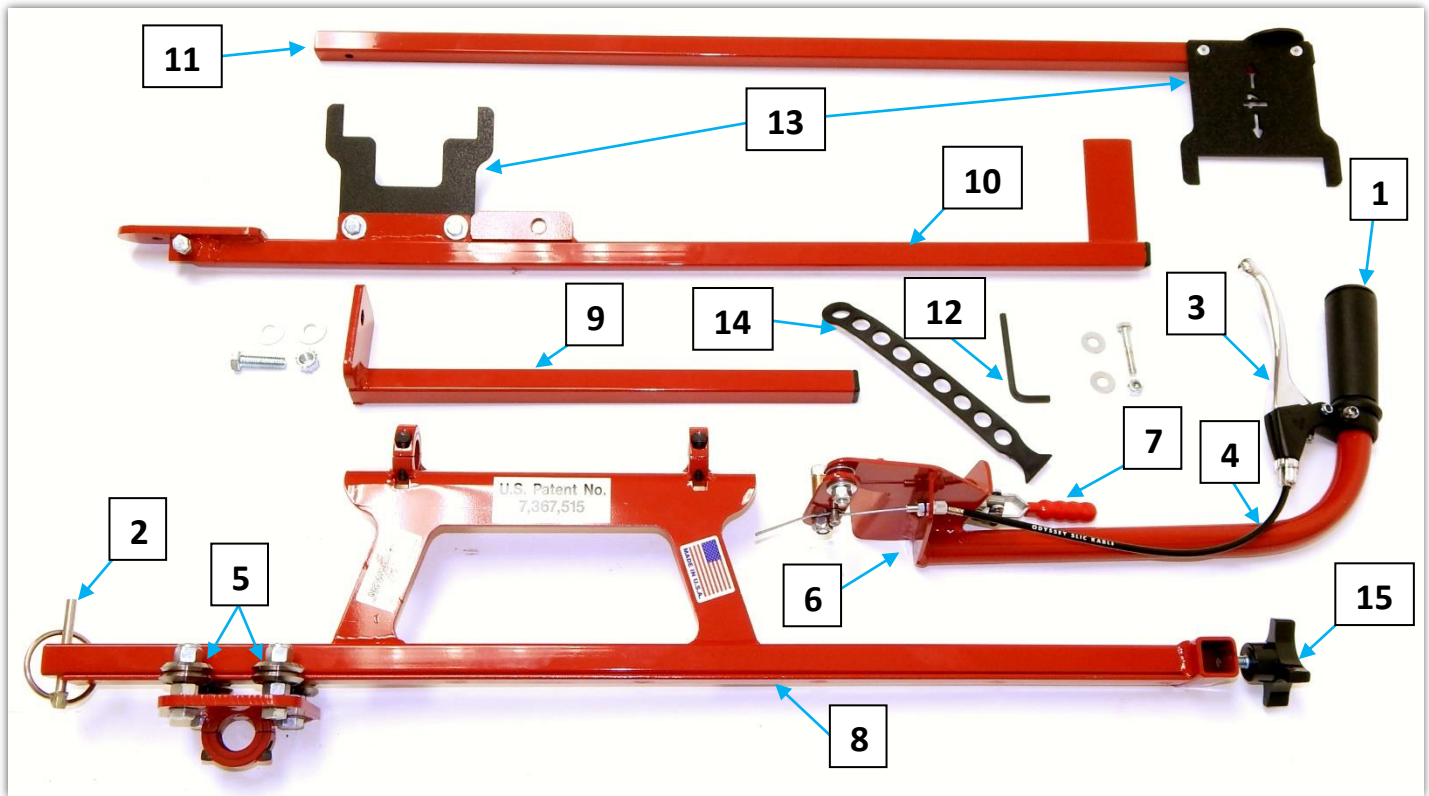

Your package should contain the items pictured. Call 1-800-624-6706 if you are missing any items.

<u>Item</u>	<u>Description</u>	<u>Part Number</u>
1	Hand Grip	10004281
2	1/4" x 2-1/8" Lynchpin	10004805
3	Spray Control Lever	10002951
4	Spray Control Cable	10002358
5	Roller Bearing (4 Required)	10004802
6	Gun Mount & Handle (No Parts Included)	10004794
7	Gun Mount Clamp	10005152
8	Rail	10004991
9	Down Tube	10004993
10	Front Guide Tube	10004994
11	Rear Guide Tube	10004995
12	3/16" Hex Wrench	10000889
13	Replacement Guide Plates & Wheel Set	10004797
14	Hose Strap	10004830
15	Star Knob	10000007



1700 Jasper St., Unit F, Aurora, CO 80011 T 800.624.6706 F 303.364.7796 • Newstripe.com

HashMark-Master II™ HP Manual / 4800.0123

HashMark-Master II™ HP

ALWAYS wear safety goggles or protective eyewear when operating the unit!

ASSEMBLY & ADJUSTMENT

Step 1

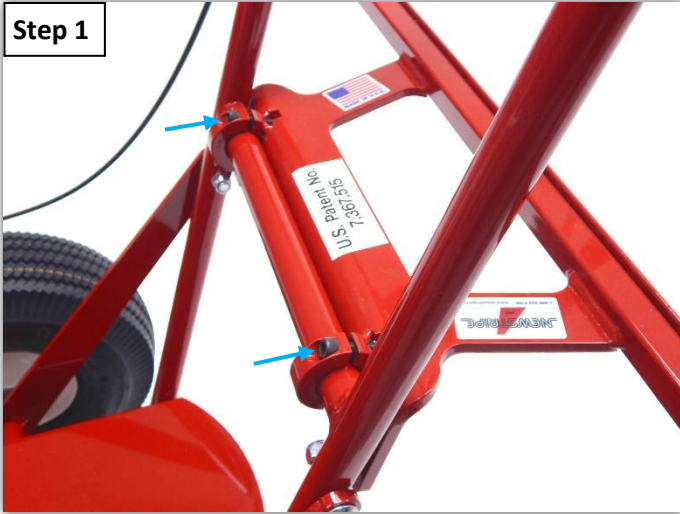

Step 1: Mount the rail to the handle using the provided hex wrench.

Step 2

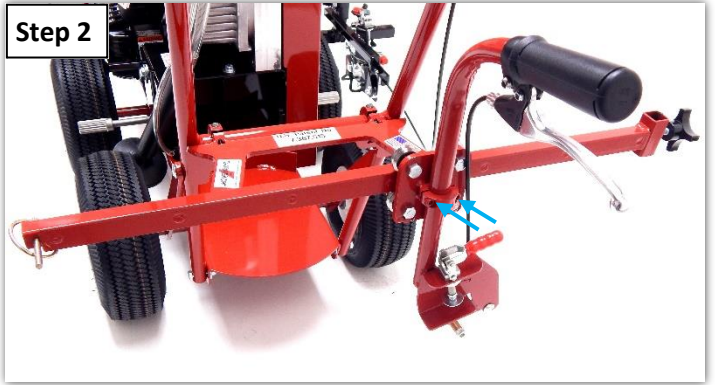

Step 2: Install the gun mount assembly into the collar carriage using the provided hex wrench. Tighten the screws just enough to hold it in place.

Step 3



Step 3: Install the downtube in the receiver at the right side of the rail. The plate on the bottom of the downtube should have the bolt hole toward the front of the machine. Adjust the down tube so that the plate is about 4" off the ground and then tighten the star knob.

Step 4



Step 4: Wrap the hose with the provided strap so that the hose does not contact the rail as the carriage moves.



1700 Jasper St., Unit F, Aurora, CO 80011 T 800.624.6706 F 303.364.7796 • Newstripe.com

HashMark-Master II™ HP Manual / 4800.0123

HashMark-Master II™ HP

ALWAYS wear safety goggles or protective eyewear when operating the unit!

ASSEMBLY & ADJUSTMENT CONTINUED

Step 5

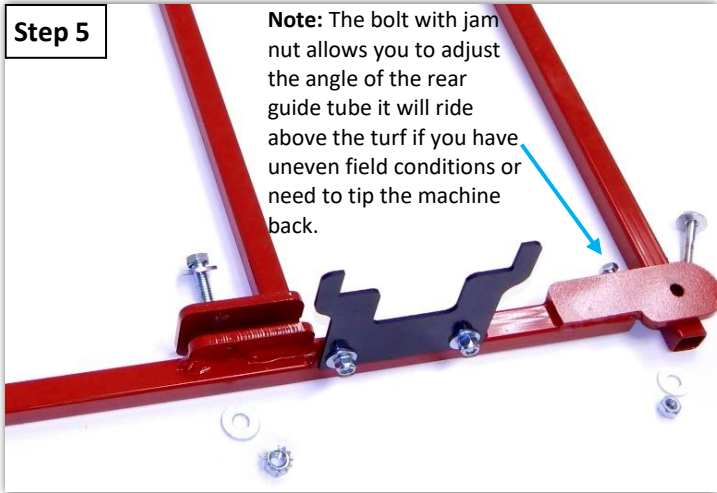

Note: The bolt with jam nut allows you to adjust the angle of the rear guide tube it will ride above the turf if you have uneven field conditions or need to tip the machine back.

Step 6



Step 5: Mount the front guide tube to the bottom of the down tube, with the plastic guide tab and the pivot to the rear as shown. Align the guide tube and down tube plates and then secure them together with a 3/8-16 x 1-1/4" bolt, two flat washers and a 3/8-16 lock nut. Just snug it at this time so that you can align the three guide tabs with an existing line or string later. Mount the rear guide tube to the pivot plate on the rear of the front guide tube with a 1/4-20 x 1-1/2" bolt, two washers and a 1/4-20 lock nut.

Step 6: Remove the spray gun from the gun mount of the machine, and place it in the gun mount of the HashMark Master™. Secure it in the gun mount with the gun mount clamp.

Step 7

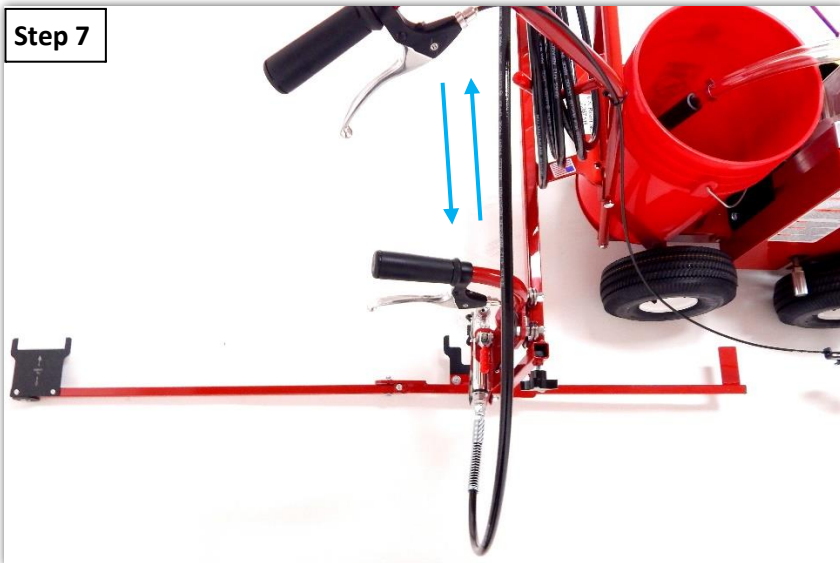

Step 7: Roll the carriage back and forth on the rail to make sure that there is no interference with the paint hose. Open the strap holding the coiled paint hose and adjust it if necessary.



1700 Jasper St., Unit F, Aurora, CO 80011 T 800.624.6706 F 303.364.7796 • Newstripe.com

HashMark-Master II™ HP Manual / 4800.0123

HashMark-Master II™ HP

ALWAYS wear safety goggles or protective eyewear when operating the unit!

OPERATION

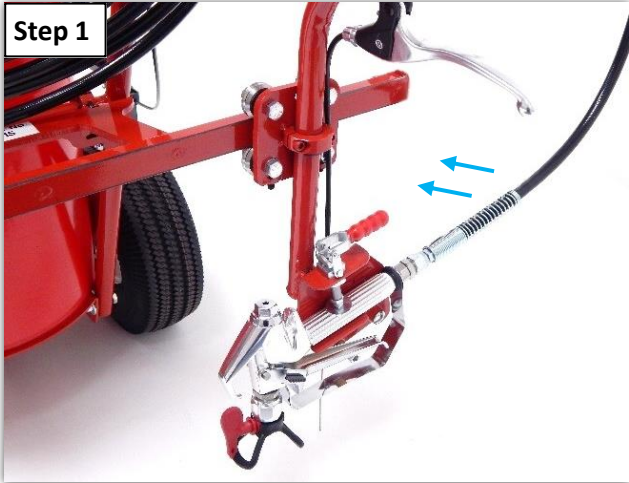

Step 1: Loosen the screws on the carrier and then raise or lower the gun mount assembly until a 4" wide line is made, when you spray.

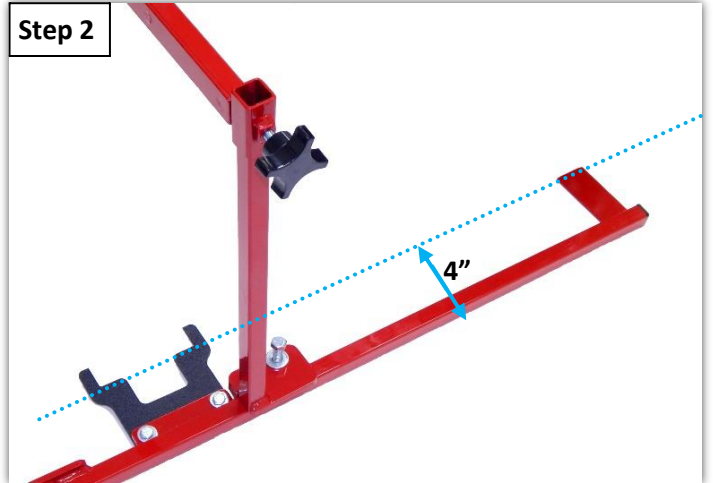

Step 2: Unfold the line guide. For a 4" inset, align the outside edge of the line guide with the sideline.

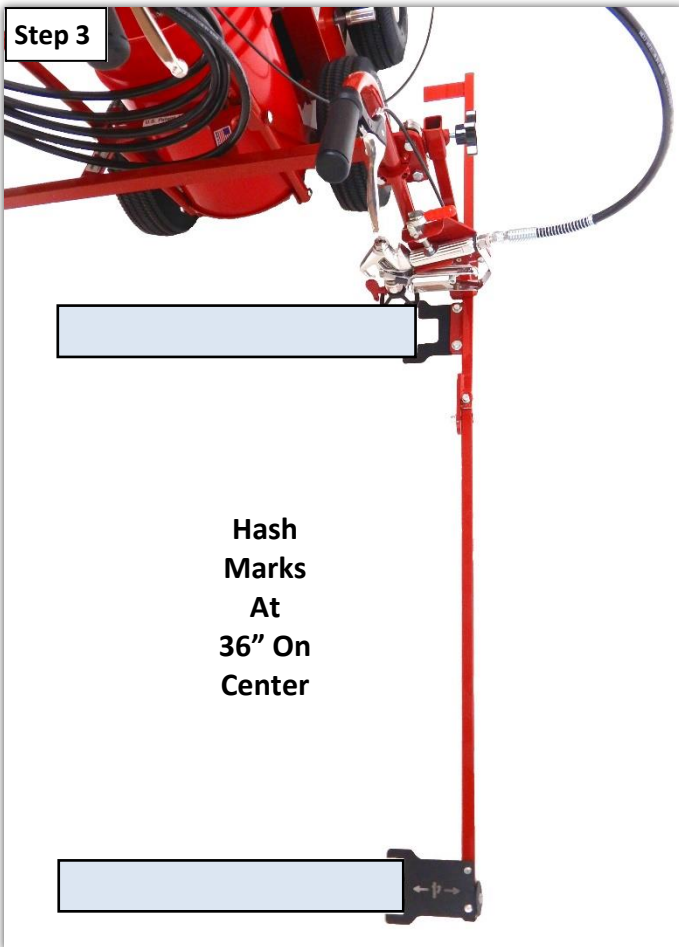

Step 3: Position the machine with the cutout of the rear line guide plate, centered over the goal line and the center of the spray tip at the left edge of the cutout of the center line guide plate. In a continuous motion, squeeze the spray lever and roll the carriage along the rail until it makes contact with the lynchpin. This will result in a 24" hash mark line.

Move the machine forward so that the rear guide is centered over the hash mark you just painted, with the left edge of the guide aligned with the start of that hash mark. Paint the next hash mark, as above and then continue to the next, in the same manner. This will create hash marks 36" apart, on center.



1700 Jasper St., Unit F, Aurora, CO 80011 T 800.624.6706 F 303.364.7796 • Newstripe.com

HashMark-Master II™ HP Manual / 4800.0123

HashMark-Master II™ HP

ALWAYS wear safety goggles or protective eyewear when operating the unit!

STOWING PROCEDURE

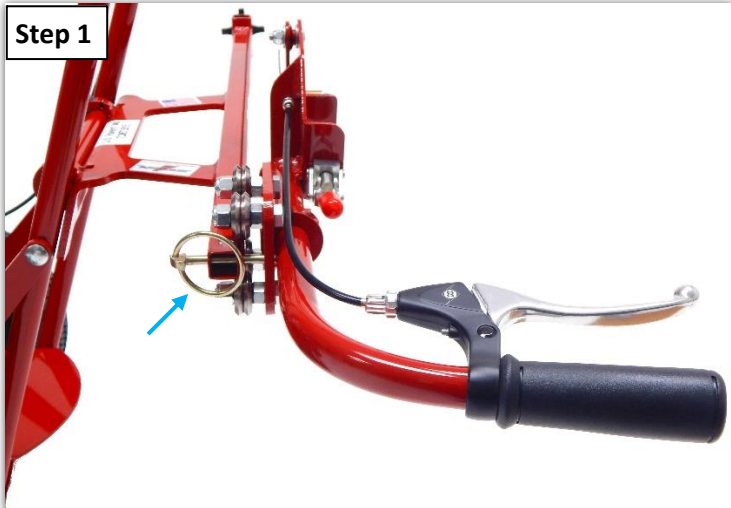

Step 1: Remove the spray gun from the HashMark Master™ and place it back into the gun mount of the machine. Remove the lynchpin and roll the carriage and gun mount assembly off of the rail. Rotate the carriage and gun mount assembly 90 degrees, and then roll it back onto the rail. Install the lynchpin through the rail and into the hole in the carriage plate, as shown.

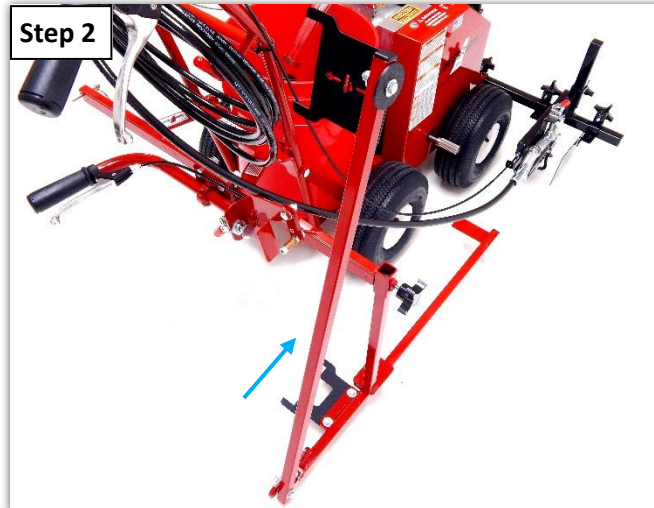

Step 2: Rotate the rear line guide tube upward, and allow it to rest against the front line guide tube, out of the way as shown.

HASH MARK STANDARDS

Hash marks for professional and college fields are located 4" from the sidelines and are 24" in length. Many High School fields are now following many of the NCAA standards. However, some schools still have hash marks touching the sidelines. Follow your local league recommendations for field layout.



1700 Jasper St., Unit F, Aurora, CO 80011 T 800.624.6706 F 303.364.7796 • Newstripe.com

HashMark-Master II™ HP Manual / 4800.0123

HashMark-Master II™ HP

ALWAYS wear safety goggles or protective eyewear when operating the unit!

AIRLESS SPRAY GUN DETAIL

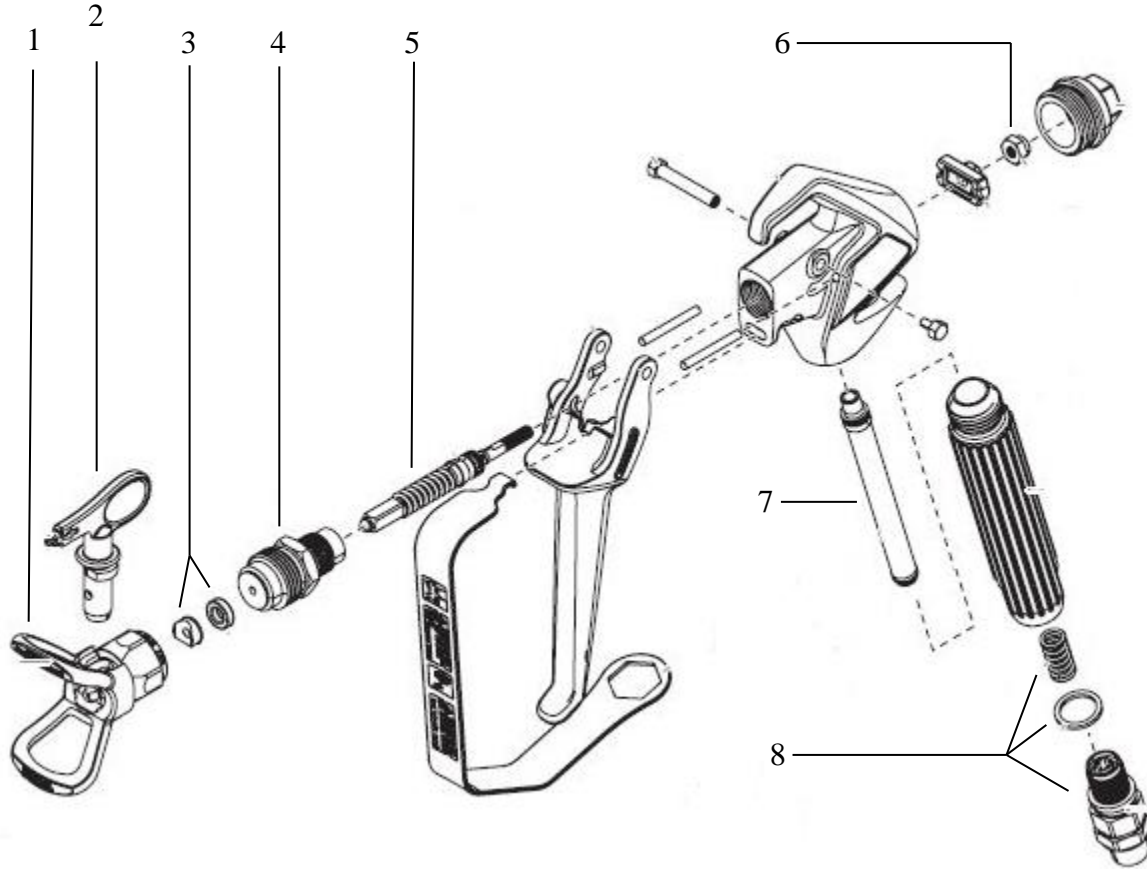

#	Part Number	Description
1	10005116	SPRAY TIP GUARD
2	10002103	319 SPRAY TIP - STANDARD FOR GPS AND SKID MOUNTED STRIPERS
	10000508	517 SPRAY TIP - STANDARD FOR WALK BEHIND STRIPERS
	10004860	519 SPRAY TIP - STANDARD TIP FOR RIDE ON STRIPERS
	10003824	619 SPRAY TIP - ALLOWS FOR WIDER LINES THAN 517 & 519 SPRAY TIPS
3	10005119	TIP SEAL KIT, PACKAGE OF 5
4	SEE # 9	7/8" DIFFUSER
5	SEE # 9	SEAL NEEDLE ASSEMBLY
6	SEE # 9	LOCK NUT
7	10000641	50 MESH GUN FILTER - STANDARD FILTER FOR STRIPERS
	10004384	OPTIONAL 30 MESH COARSE GUN FILTER
8	10005135	SWIVEL FITTING KIT
9	10005117	AIRLESS SPRAY GUN REPAIR (Includes Item Numbers 4, 5, and 6)



1700 Jasper St., Unit F, Aurora, CO 80011 T 800.624.6706 F 303.364.7796 • Newstripe.com

HashMark-Master II™ HP Manual / 4800.0123

HashMark-Master II™ HP

ALWAYS wear safety goggles or protective eyewear when operating the unit!

THE NEWSTRIPE WARRANTY – 18 MONTH

NEWSTRIPE, INC., WARRANTS TO THE ORIGINAL PURCHASER, FOR 18 (EIGHTEEN) MONTHS AFTER DATE OF PURCHASE, THAT THE EQUIPMENT* HEREBY SOLD SHALL BE FREE OF DEFECTS IN MATERIALS AND WORKMANSHIP. THIS WARRANTY DOES NOT EXTEND TO ANY DAMAGE OR MALFUNCTION RESULTING FROM MISUSE, NEGLIGENCE, ACCIDENT, IMPROPER OPERATION, OR NORMAL WEAR AND TEAR.

Damage incurred in shipment from Newstripe, Inc. to the customer is the total responsibility of the carrier. The CUSTOMER MUST NOTE DAMAGES on the Bill of Lading of Trucking Company or Railroad; and Newstripe, Inc. will furnish to the customer the cost or parts and labor. The customer can then bill the common carrier for the damages by placing his signature on the documents.

The Newstripe, Inc. obligation under this warranty and any implied warranties is limited to replacement or repair of defective parts of its manufacture without charge for 18 (EIGHTEEN) months from date of purchase. For service under this warranty, buyer shall ship the defective part or parts of the equipment, transportation prepaid, to Newstripe, Inc. together with a written description of any claimed defect and proof of purchase date of the materials being returned. **Prior to retuning any part or machine, the CUSTOMER must obtain a Return Materials Authorization number. Call 1-800-624-6706. To review the complete guidelines for warranty and returns, please visit www.newstripe.com/terms-of-use-privacy-policy.**

***Components not manufactured by Newstripe, Inc. such as engines, compressors, pumps, and transaxles are furnished with their respective manufacturer's warranties only. Where Newstripe elects to extend manufacturers' warranties, the warranty shall cover up to 100% of the cost to repair or replace materials and parts for the first 12 months of ownership, excluding labor. Extension of any manufacturers' warranty for these components is at the sole discretion of Newstripe, Inc. and does not include wearable parts and consumable components from normal wear and tear.**

The responsibilities described above are the only responsibilities of Newstripe, Inc. under this written warranty or any implied warranty, and may be exercised only within 18 (EIGHTEEN) months from the date of purchase. In no event shall Newstripe, Inc. be liable for incidental or consequential damages and no person had any authority to bind it to any representation or warranty, not be responsible for work done, materials furnished or repairs made by others without its' specific written authorization.

THIS WARRANTY SHALL BE IN LIEU OF ANY AND ALL OTHER WARRANTIES, EXPRESSED OR IMPLIED, INCLUDING ANY WARRANTIES OF MERCHANTABILITY OR FITNESS FOR A PARTICULAR PURPOSE, AND THERE IS NO OTHER REPRESENTATION OR WARRANTY OF ANY KIND WITH RESPECT TO THE GOODS SOLD HEREBY EXCEPT AS SET FORTH HEREIN. IT IS EXPRESSLY AGREED THAT THIS WARRANTY SHALL BE LIMITED TO THE ADJUSTMENT, REPAIR OR REPLACEMENT OF PARTS AND THE LABOR AND SERVICES REQUIRED THEREBY. IN NO EVENT, INCLUDING ANY CLAIM FOR NEGLIGENCE, SHALL NEWSTRIPE, INC. BE LIABLE FOR INCIDENTAL OR CONSEQUENTIAL DAMAGES.

Sincerely,
Newstripe, Inc.



1700 Jasper St., Unit F, Aurora, CO 80011 T 800.624.6706 F 303.364.7796 • Newstripe.com

HashMark-Master II™ HP Manual / 4800.0123