



Product Manual

PackMaster™ Air Powered Compactor

10001259



Proudly Made in the USA
Newstripe.com • 303-364-7786

1259.0426

PackMaster™ Air Powered Compactor

TABLE OF CONTENTS

Precautionary Warnings	Page 1
Assembly	Page 2-3
Operation	Page 4
Parts List.....	Page 5
Safety Control Arm Assembly	Page 6
Warranty.....	Page 7

Thank you for purchasing the Newstripe PackMaster™ Air Powered Compactor.

Please read over the instructions and make sure you understand the operating procedures before using the unit.

Please check the serial number on your unit. This Manual is for units with serial number 1025585 and above only. For units with serial numbers below 1025585, please contact Newstripe for the correct manual.



PackMaster™ Air Powered Compactor



PRECAUTIONARY WARNINGS

- **PLEASE** read and understand all operation instructions as detailed in this manual. Failure to follow specified instructions may result in equipment damage or severe injury to personnel.
- **DO NOT** crush glass containers, items that may shatter, or items that contain volatile vapors.
- **DO NOT** modify or change the controls in any way. Dropping the control arm at any time will stop the movement of the ram plate. Changing the controls of the unit may result in personal injury.
- **DO NOT** exceed 150 psi. Failure to adhere to this may result in equipment damage or personal injury.
- **DO NOT** bolt the PackMaster to the floor. This will cause damage to the unit and may result in personal injury.
- **ALWAYS** keep your arms & hands away from the compactor ram and drum lip while compacting. Failure to do so may cause personal injury.
- **ALWAYS** make sure the air supply line is disconnected before performing any cleaning or maintenance on the compactor. With the airline disconnected, the ram plate may gradually lower after an extended period.
- **ALWAYS** keep compacted waste drums away from heat, sparks, and flames. No smoking near the unit.
- **PLEASE** keep the pivot points of the control arm lubricated with a light machine oil.
- **ALWAYS** consult your Facility Safety and/or Personnel Department for specified safety protocols prior to operating this equipment.

PackMaster™ Air Powered Compactor

Your PackMaster™ Air Powered Compactor package contains the following:

In Box

- Base Plate
- Upright Arms (2)
- Air Cylinder Assembly
- Air Cylinder Mounting Plate
- Ram Plate
- Control Arm w/ Mounting Bracket

In Parts Bag

- (5) ½" x 2" Long Bolts
- (5) ½" x 1 ½" Long Bolts
- (16) ½" Washers
- (10) ½" Lock Nuts
- (1) Product Manual

ASSEMBLY

1. Mount the uprights on the base plate with (4) ½" x 1 ½" long bolts, (8) ½" flat washers and (4) ½" nylock nuts.

Note: Do not fully tighten bolts at this time. This will aid in mounting the cylinder assembly.

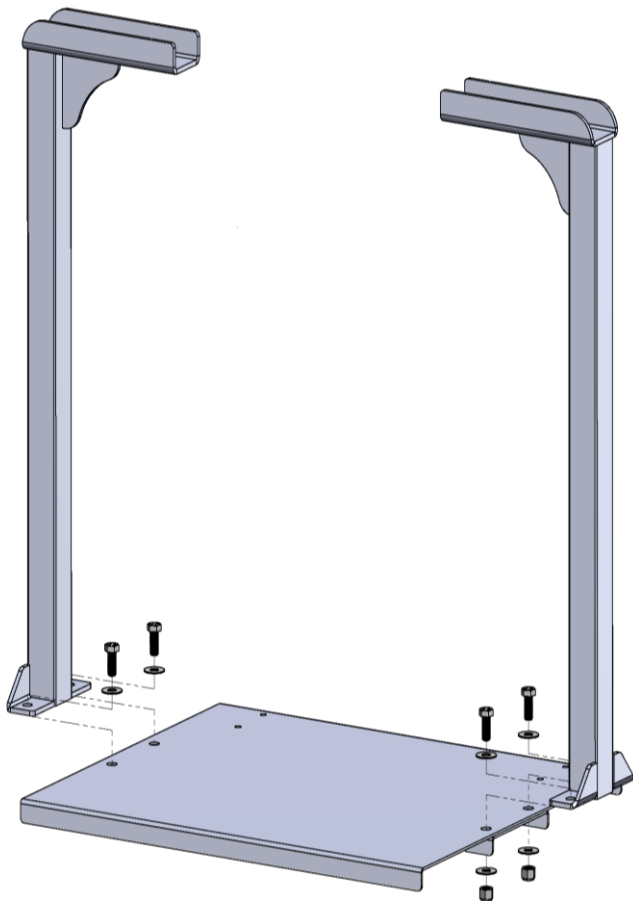

2. Install the control arm and the cylinder plate to the two uprights using (1) ½" x 1 ½" long bolt, (2) ½" washers, and (1) locking nut, on the right side, and (1) ½" x 2" long bolt, (2) ½" washers, and (1) locking nut on the left side, with the bracket.

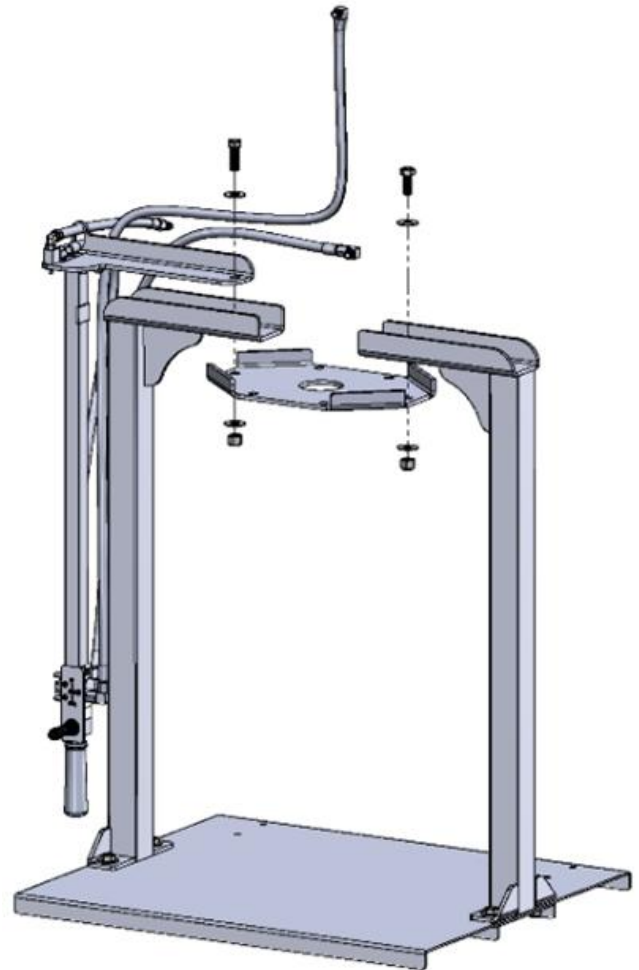

PackMaster™ Air Powered Compactor

ASSEMBLY CONTINUED

3. Mount the air cylinder to the air cylinder mounting plate using (4) ½" x 2" long bolts, (4) ½" washers on the bottom side, and (4) locking nuts. The air supply fittings should face away from you. Tighten all air cylinder assembly and upright mounting bolts.

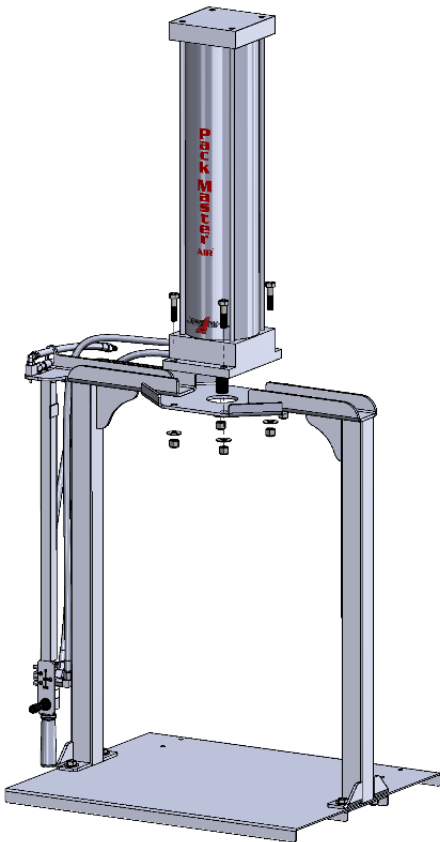

5. Insure that the jam nut is spun all the way up on the threaded portion of the air cylinder rod by hand. Thread the ram plate onto the air cylinder rod until it is snug. Spin the jam nut back down against the ram plate and then tighten it.

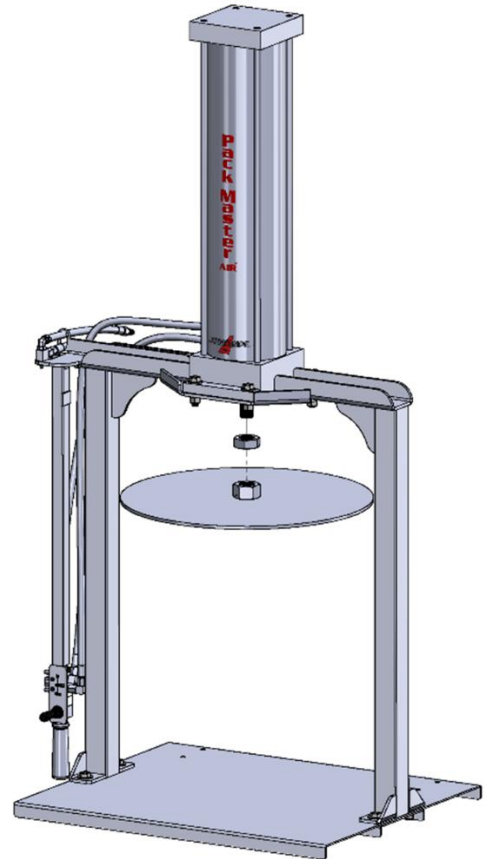

4. Connect the long air hose to the top fitting, and the short hose to the bottom fitting, on the backside of the air cylinder.



6. Connect the PackMaster to an air supply source with a maximum pressure of 150 psi.

Note: The PackMaster is supplied with a pigtail hose and standard male quick-disconnect fitting for connection air supply hose. If the unit is stationary, you may remove the pigtail hose and hard-plumb the unit to an air supply line if you wish. Minimum operating pressure is 85 psi.

PackMaster™ Air Powered Compactor

OPERATION

1. Place a 55-gallon waste drum under the ram plate of the unit (or a 30-gallon drum with optional 17" ram plate).



2. Lift the safety control arm to a horizontal position, against the stop on the unit. This assures that the safety valve plunger is fully depressed.

Note: The safety valve plunger must be fully depressed to provide air from the control valve to the cylinder, or the unit will not operate.



3. Move the ram control valve lever toward the handle end, (backwards) to lower the ram plate. Release the ram control valve lever, and the ram plate will stop. Move the ram control valve lever toward the unit (forward) to raise the ram.

Note: The control arm must be continuously held up in the horizontal position to engage the safety valve for the ram plate to move.



PackMaster™ Air Powered Compactor

PARTS LIST

Item	Description	Part Number
1	Upright	1000988
2	Base Plate	10004752
3	Control Arm Bracket	10001018
4	Hose Assembly, Supply, 12"	10001421
5	Hose Assembly, Lower, 56"	10001423
6	Hose Assembly, Upper, 75"	10004150
7	Air Cylinder Plate	10001019
8	Hose Assembly, Control 44-1/2"	10001422

Item	Description	Part Number
9	Safety Control Arm Assembly	10001020
10	Ram Control Valve	10005138
11	Safety Control Valve	10000609
12	Air Cylinder Assembly	10001846
13	Ram Plate 20"	10001524
Optional	Ram Plate 17"	10001515
14	1 ¼ -12 Jam Nut	10001837
15	Hand Grip	10004281

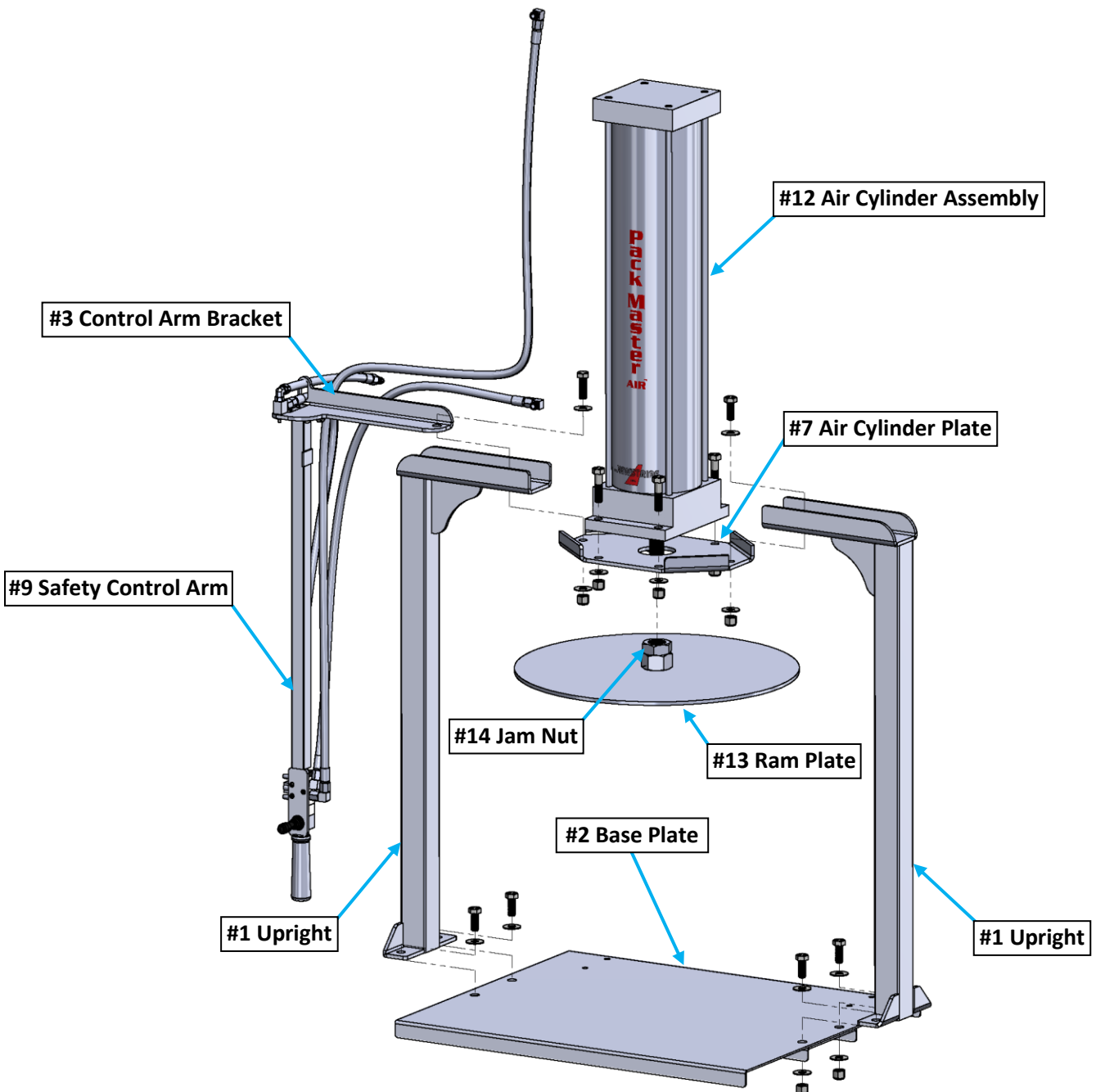

PackMaster™ Air Powered Compactor

Safety Control Arm Assembly

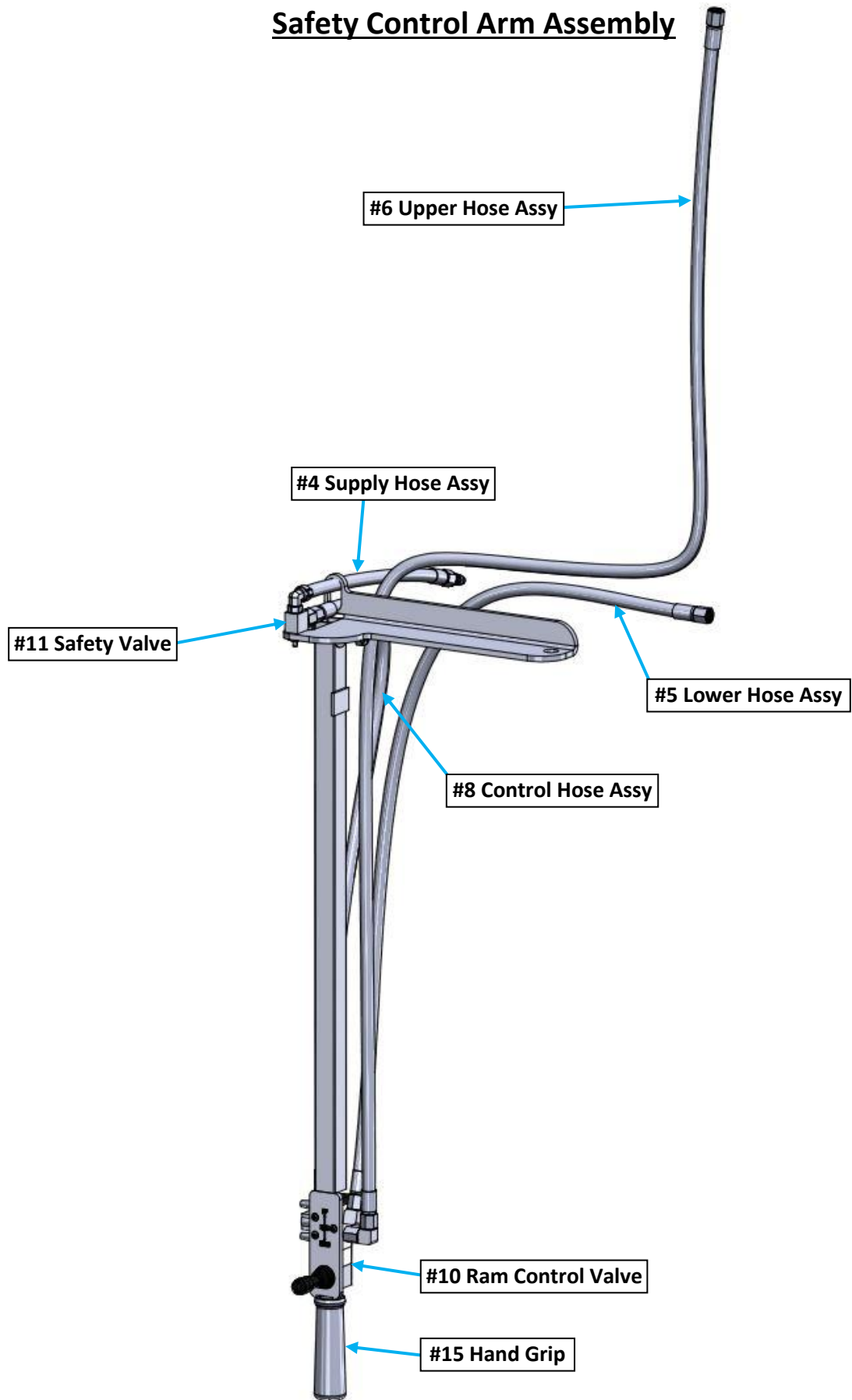

PackMaster™ Air Powered Compactor

10001259

18 Month Warranty

Newstripe, Inc. ("Newstripe") warrants to the original purchaser, for 18 (Eighteen) Months after date of purchase, that the equipment* hereby sold shall be free of defects in materials and workmanship. This warranty does not extend to any damage or malfunction resulting in misuse, neglect, accident, improper operation, or normal wear and tear.

* Gasoline engines, compressors, low pressure pumps, and transaxles are furnished with their respective manufacturers' warranties only and are not covered by any warranty of Newstripe. High pressure pumps manufactured by Newstripe (excluding wear items like diaphragms and valves) are warranted for materials and workmanship for 12 Months after the date of purchase.

Damage incurred in shipment from Newstripe to the purchaser is the total responsibility of the shipping carrier. The purchaser is responsible for noting any damages on the Bill of Lading of the shipping carrier and Newstripe will work with the shipping carrier to resolve any damages incurred.

The Newstripe obligation under this warranty and any implied warranties is limited to replacement or repair of defective parts of its manufacture without charge for 18 (Eighteen) Months from date of purchase. For service under this warranty, the purchaser shall obtain an approved Return Materials Authorization (RMA) from Newstripe and then ship the defective part or parts of the equipment, transportation prepaid by the purchaser, to Newstripe together with a written description of any claimed defect and proof of purchase date of the materials being returned. To review Newstripe's complete guidelines for warranty claims and returns, please visit our website at www.newstripe.com.

The responsibilities described above are the only responsibilities of Newstripe under this written warranty or any implied warranty and may be exercised only within 18 (Eighteen) Months from the date of original purchase. In no event shall Newstripe be liable for incidental or consequential damages and no person has any authority to bind it to any representation or warranty. Newstripe is not responsible for work done, materials furnished, or repairs made by others without its specific written authorization.

This warranty shall be in lieu of any and all other warranties, expressed or implied, including any warranties of merchantability or fitness for a particular purpose, and there is no other representation or warranty of any kind with respect to the goods sold hereby except as set forth herein. It is expressly agreed that this warranty shall be limited to the adjustment, repair or replacement of parts and the labor and services required thereby. In no event, including any claim of negligence, shall Newstripe be liable for incidental or consequential damages.



Newstripe.com / 303-364-7786