

PackMaster™

Product Manual



PackMaster Manual

ALWAYS wear safety goggles or protective eyewear when operating the unit!



The PackMaster is not designed for crushing glass containers or items that may shatter or contain volatile vapors. The PackMaster is also not designed for crushing drums.

TABLE OF CONTENTS

Precautionary Warning.....	Page 1
Assembly.....	Page 2-3
Operation.....	Page 4
Parts List.....	Page 5
Warranty.....	Page 8

Thank you!

Congratulations on your purchase of the PackMaster industrial trash compactor.

Please take time to read over the instructions and make sure you have all the necessary parts before assembling. Once assembled, you will have an efficient tool to reduce waste volume for many years.

Please check the serial number on your unit. This manual is for units with serial number 1025739 and above only. For units with serial numbers below 1025739, please contact Newstripe for the correct manual.



1700 Jasper St., Unit F, Aurora, CO 80011 T 800.624.6706 F 303.364.7796 • Newstripe.com

PackMaster™ Owner's Manual / 1258.1023

PackMaster Manual

ALWAYS wear safety goggles or protective eyewear when operating the unit!



PRECAUTIONARY WARNINGS!

- Please read and understand all operation instructions as detailed in this manual. Failure to follow specified instructions may result in equipment damage or severe injury to personnel.
- The PackMaster is not designed for crushing glass containers or items that may shatter or contain volatile vapors.
- Keep the jack rail lubricated with General Purpose EP grease.
- Keep compacted waste drums away from heat, sparks, and flames – No smoking.
- Always consult your Facility Safety and/or Personnel Department for specified safety protocols prior to operating this equipment.
- DO NOT extend or modify the jack handle in any way (e.g., cheater bar).
- DO NOT permanently bolt the Pack-Master to the floor as damage to the unit and personal injury may occur.
- ALWAYS hold on to the jack handle while compacting. Jack handle may “SPRING” up when under load and pins have not snapped all the way into the jack rail.
- ALWAYS engage the handle lock when moving the levers, or the jack handle may fall suddenly, causing injury.
- ALWAYS keep your head out of the path of the jack handle!
- Failure to adhere to the following statements about unsafe practices may cause hazards that cause severe injury.



1700 Jasper St., Unit F, Aurora, CO 80011 T 800.624.6706 F 303.364.7796 • Newstripe.com

PackMaster™ Owner's Manual / 1258.1023

Page 1 of 8

PackMaster Manual

ALWAYS wear safety goggles or protective eyewear when operating the unit!

Your PackMaster™ Manual package contains the following:

Box:

- Base Plate
- Upright Arms (2)
- Jack Assembly
- Ram Plate w/ Bolt & Nut

Parts Bag Containing:

- (6) ½-13 x 1 ½" Long Bolts
- (6) ½-13 Nylock Nuts
- (12) ½" Flat Washers
- (1) Owner's Manual

ASSEMBLY

- 1) Mount the uprights to the base plate using (4) ½" x 1 ½" long bolts, (8) ½" flat washers and (4) ½" nylock nuts. (NOTE: Do not tighten bolts all the way, so the jack assembly may be installed).

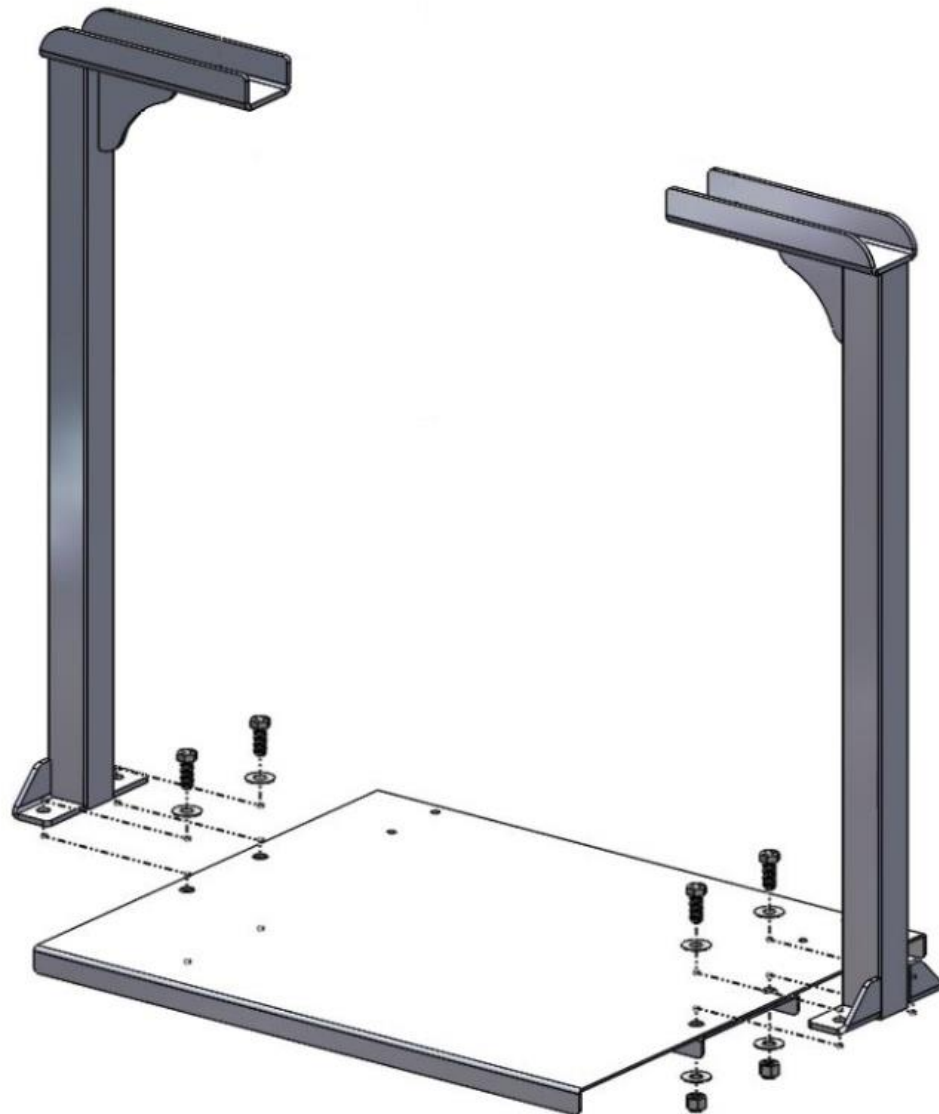

1700 Jasper St., Unit F, Aurora, CO 80011 T 800.624.6706 F 303.364.7796 • Newstripe.com

PackMaster™ Owner's Manual / 1258.1023

Page 2 of 8

PackMaster Manual

ALWAYS wear safety goggles or protective eyewear when operating the unit!

- 2) Install the jack plate to the arms using (2) $\frac{1}{2}$ " x 1- $\frac{1}{2}$ " long bolts, (4) $\frac{1}{2}$ " flat washers, and (2) $\frac{1}{2}$ " nylock nuts. *Note: The jack tongue plate is not shown here, only to make viewing of the left mounting bolt easier. The tongue plate will come assembled on the jack assembly.*

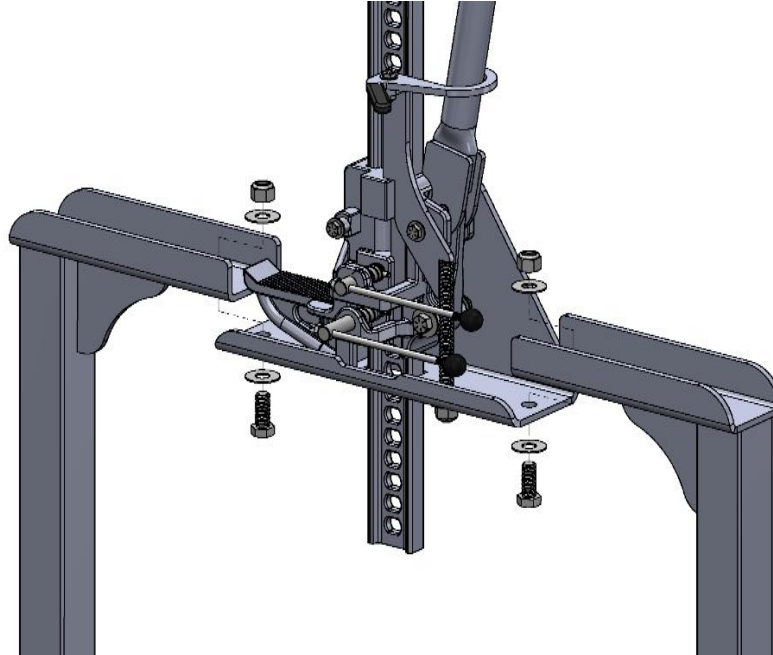

- 3) Align the uprights and jack assembly and tighten all bolts.
- 4) Mount the ram plate to the jack assembly using (1) $\frac{1}{2}$ " x 2 $\frac{1}{2}$ " bolt and (1) $\frac{1}{2}$ " nylock nut.

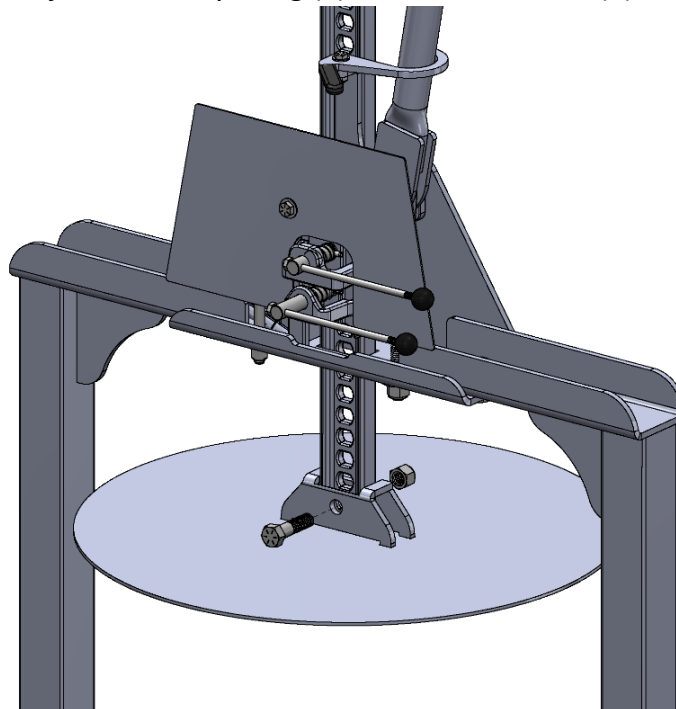

PackMaster Manual

ALWAYS wear safety goggles or protective eyewear when operating the unit!

OPERATION

- 1) To operate the PackMaster, engage the handle lock as shown.



- 2) Swing the lower lever to the “DOWN” position first, and then the upper lever to the “DOWN” position.

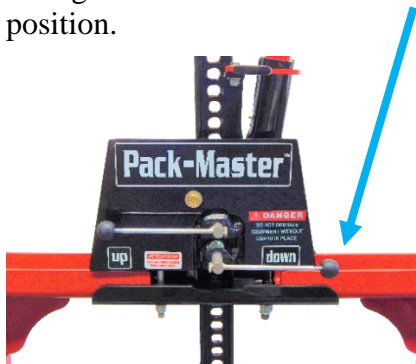

- 3) Disengage the handle lock and then begin pumping the jack handle up and down.

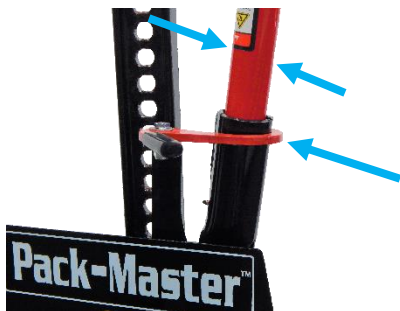

- 4) To retract the compactor plate, while applying slight downward pressure on jack handle, swing upper lever to “UP” position, then the lower lever. This removes pressure on the pin and will extend the life of the jacking pins.



PackMaster Manual

ALWAYS wear safety goggles or protective eyewear when operating the unit!

PARTS LIST

Item	Description	Part #
1	Upright	10000988
2	Base Plate	10004752
3	Jack Assembly	10001017
4	Ram Plate (20" Dia.)	10001428
Optional	Ram Plate (17" Dia.)	10001288
5	Handle Lock Hook	10000774
6	Jack Support Stud	10000773
7	4" Jack Pin w/lever (lower)	10001568
8	3" Jack Pin w/lever (upper)	10001567
9	Shear Pin w/Nut	10001096

Item	Description	Part #
10	Handle Socket	10001093
11	Spring, Jack Pins	10001305
12	Pitman Pin	10001094
13	Pitman Arm	10001095
14	Handle Socket Bolt	10004921
15	Handle Socket Nut	10001286
16	Roll Pin, Jack Pins	10001569
17	Jack Face Plate	10000989
18	Jack Tongue Plate	10001016
19	Jack Handle (Part of Jack)	N/A

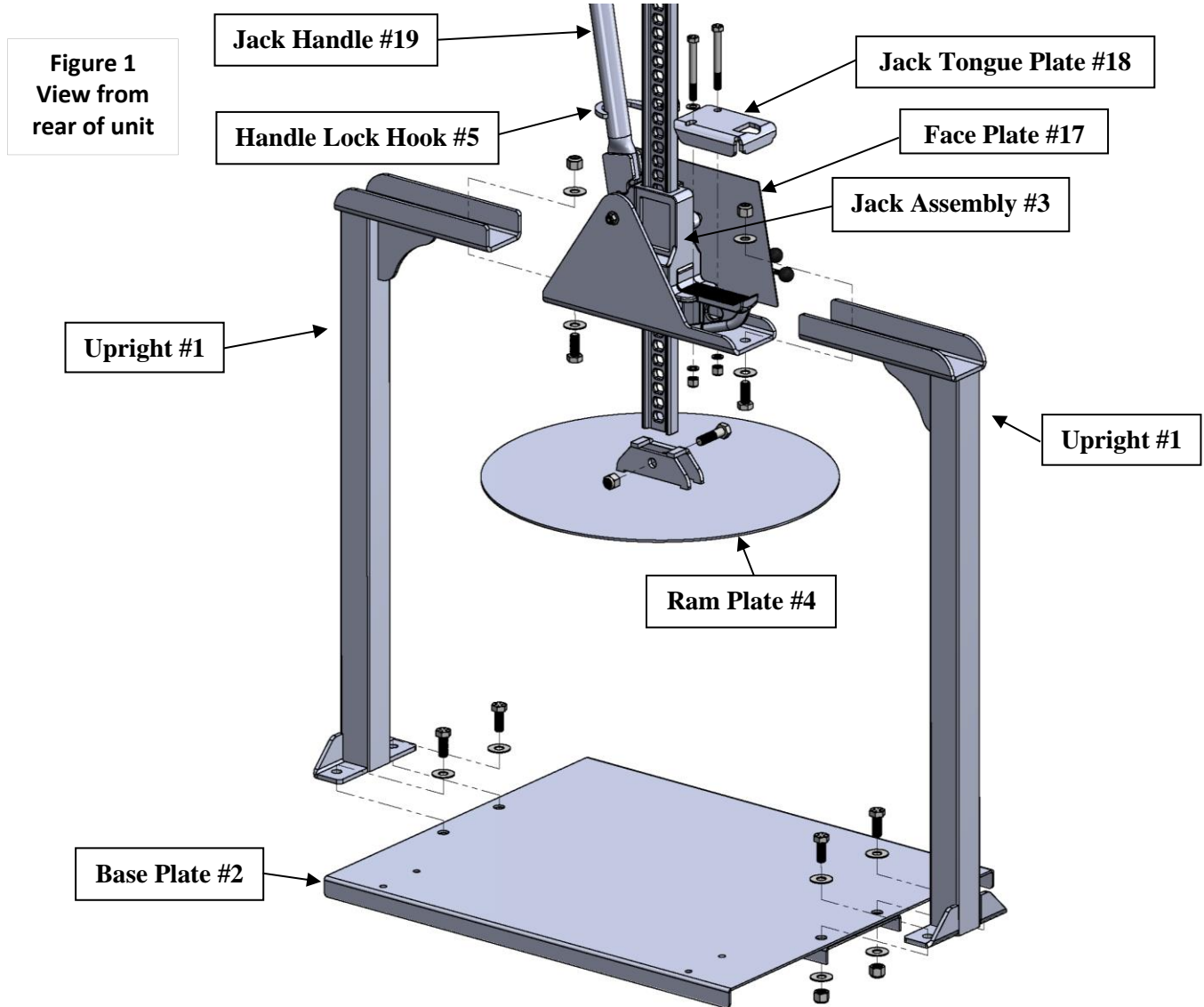

1700 Jasper St., Unit F, Aurora, CO 80011 T 800.624.6706 F 303.364.7796 • Newstripe.com

PackMaster™ Owner's Manual / 1258.1023

Page 5 of 8

PackMaster Manual

ALWAYS wear safety goggles or protective eyewear when operating the unit!

Figure 2
View from
front of unit

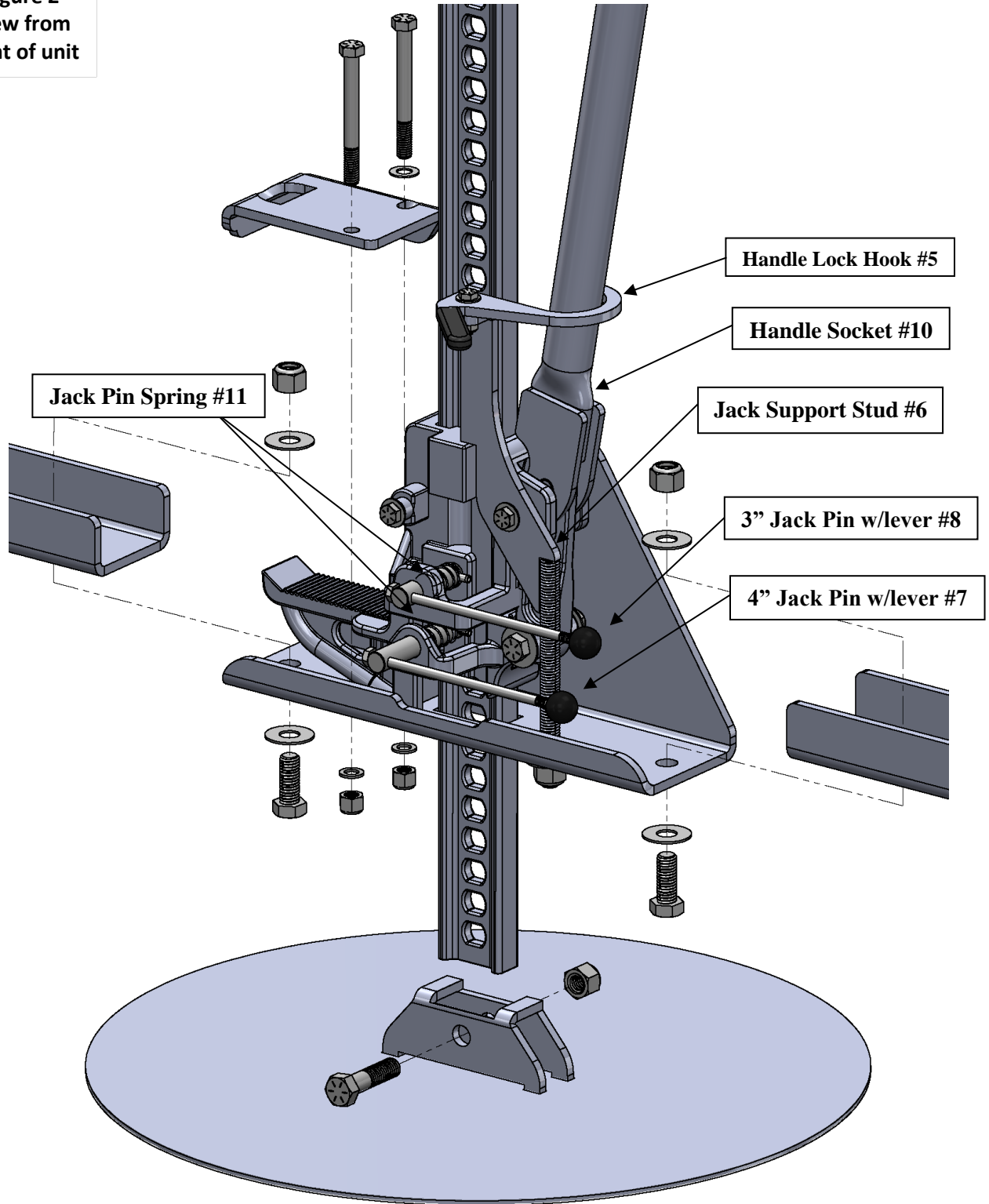

1700 Jasper St., Unit F, Aurora, CO 80011 T 800.624.6706 F 303.364.7796 • Newstripe.com

PackMaster™ Owner's Manual / 1258.1023

PackMaster Manual

ALWAYS wear safety goggles or protective eyewear when operating the unit!

Figure 3
View from
front of unit

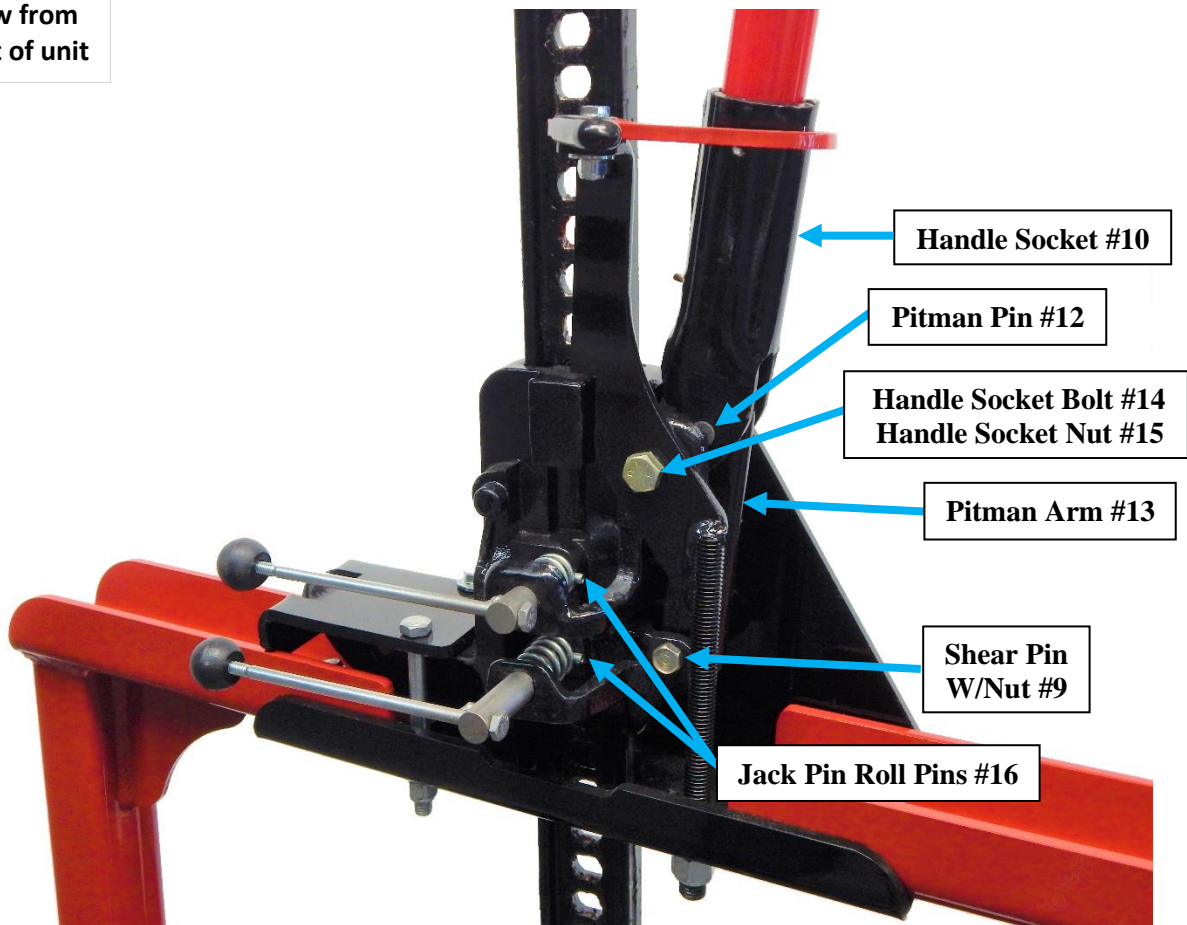

1700 Jasper St., Unit F, Aurora, CO 80011 T 800.624.6706 F 303.364.7796 • Newstripe.com

PackMaster™ Owner's Manual / 1258.1023

Page 7 of 8

PackMaster Manual

ALWAYS wear safety goggles or protective eyewear when operating the unit!

THE NEWSTRIPE WARRANTY – 18 MONTH

NEWSTRIPE, INC., WARRANTS TO THE ORIGINAL PURCHASER, FOR 18 (EIGHTEEN) MONTHS AFTER THE DATE OF PURCHASE, THAT THE EQUIPMENT* HEREBY SOLD SHALL BE FREE OF DEFECTS IN MATERIALS AND WORKMANSHIP. THIS WARRANTY DOES NOT EXTEND TO ANY DAMAGE OR MALFUNCTION RESULTING FROM MISUSE, NEGLIGENCE, ACCIDENT, IMPROPER OPERATION, OR NORMAL WEAR AND TEAR.

Damage incurred in shipment from Newstripe, Inc. to the customer is the total responsibility of the carrier. The CUSTOMER MUST NOTE DAMAGES on the Bill of Lading of Trucking Company or Railroad; and Newstripe, Inc. will furnish to the customer the cost or parts and labor. The customer can then bill the common carrier for the damages by placing his signature on the documents.

The Newstripe, Inc. obligation under this warranty and any implied warranties is limited to replacement or repair of defective parts of its manufacture without charge for 18 (Eighteen) months from date of purchase. For service under this warranty, the buyer shall ship the defective part or parts of the equipment, transportation prepaid, to Newstripe, Inc. together with a written description of any claimed defect and proof of purchase date of the materials being returned. **Prior to returning any part or machine, the CUSTOMER must obtain a Return Materials Authorization number. Call 1-800-624-6706. To review the complete guidelines for warranty and returns, please visit www.newstripe.com/guidelinesforwarrantyandreturn.**

***Gasoline engines, compressors, pumps (including airless) and Transaxles are furnished with their respective manufacturer's warranties only. These components are not covered by any warranty of Newstripe, Inc. Where Newstripe elects to extend manufacturers' warranties, the warranty shall be prorated as to cover 100% of the cost to replace or repair materials and parts for the first 12 months of ownership and 60% for the remaining 6-month period.**

The responsibilities described above are the only responsibilities of Newstripe, Inc. under this written warranty or any implied warranty, and may be exercised only within 18 (Eighteen) months from the date of purchase. In no event shall Newstripe, Inc. be liable for incidental or consequential damages and no person had any authority to bind it to any representation or warranty, not be responsible for work done, materials furnished, or repairs made by others without its' specific written authorization.

THIS WARRANTY SHALL BE IN LIEU OF ANY AND ALL OTHER WARRANTIES, EXPRESSED OR IMPLIED, INCLUDING ANY WARRANTIES OF MERCHANTABILITY OR FITNESS FOR A PARTICULAR PURPOSE, AND THERE IS NO OTHER REPRESENTATION OR WARRANTY OF ANY KIND WITH RESPECT TO THE GOODS SOLD HEREBY EXCEPT AS SET FORTH HEREIN. IT IS EXPRESSLY AGREED THAT THIS WARRANTY SHALL BE LIMITED TO THE ADJUSTMENT, REPAIR OR REPLACEMENT OF PARTS AND THE LABOR AND SERVICES REQUIRED THEREBY. IN NO EVENT, INCLUDING ANY CLAIM FOR NEGLIGENCE, SHALL NEWSTRIPE, INC. BE LIABLE FOR INCIDENTAL OR CONSEQUENTIAL DAMAGES.

Sincerely,
Newstripe, Inc



1700 Jasper St., Unit F, Aurora, CO 80011 T 800.624.6706 F 303.364.7796 • Newstripe.com

PackMaster™ Owner's Manual / 1258.1023

Page 8 of 8