



Product Manual

PackMaster™ Manual Compactor

10001258



Proudly Made in the USA
Newstripe.com • 303-364-7786

PackMaster™ Manual Compactor

TABLE OF CONTENTS

Precautionary Warnings Page 1

Assembly Page 2

Operation Page 3

Parts List..... Page 4-5

Warranty..... Page 6

Thank you for purchasing the Newstripe PackMaster™ Manual Compactor.

Please read over the instructions and make sure you understand the operating procedures before using the unit.

Please check the serial number on your unit. This manual is for units with serial number 1025739 and above only. For units with serial numbers below 1025739, please contact Newstripe for the correct manual.



PackMaster™ Manual Compactor



PRECAUTIONARY WARNINGS

- **PLEASE** read and understand all operation instructions as detailed in this manual. Failure to follow specified instructions may result in equipment damage or severe injury to personnel.
- **DO NOT** crush glass containers, items that may shatter, or items that contain volatile vapors.
- **DO NOT** extend or modify the jack handle in any way. This will cause damage to the unit and may result in personal injury.
- **DO NOT** bolt the PackMaster to the floor. This will cause damage to the unit and may result in personal injury.
- **ALWAYS** hold onto the jack handle while compacting. The jack handle may spring upward if the pins have not fully engaged the rail.
- **ALWAYS** keep your head out of the path of the jack handle.
- **ALWAYS** engage the jack handle lock hook when rotating the jack levers. This will keep the jack handle from falling and causing injury.
- **ALWAYS** keep compacted waste drums away from heat, sparks, and flames. No smoking near the unit.
- **PLEASE** keep the jack rail lubricated with EP bearing grease.
- **PLEASE** keep all pivot points of the jack mechanism lubricated with a light machine oil.
- **ALWAYS** consult your Facility Safety and/or Personnel Department for specified safety protocols prior to operating this equipment.

PackMaster™ Manual Compactor

Your PackMaster™ Manual package contains the following:

In Box

- Base Plate
- Upright Arms (2)
- Jack Assembly
- Ram Plate w/ Bolt & Nut

In Parts Bag

- (6) ½-13 x 1 ½" Long Bolts
- (6) ½-13 Nylock Nuts
- (12) ½" Flat Washers
- (1) Product Manual

ASSEMBLY

1. Mount the uprights on the base plate with (4) ½" x 1 ½" long bolts, (8) ½" flat washers and (4) ½" nylock nuts.

Note: Do not fully tighten bolts at this time. This will aid in mounting the jack assembly.

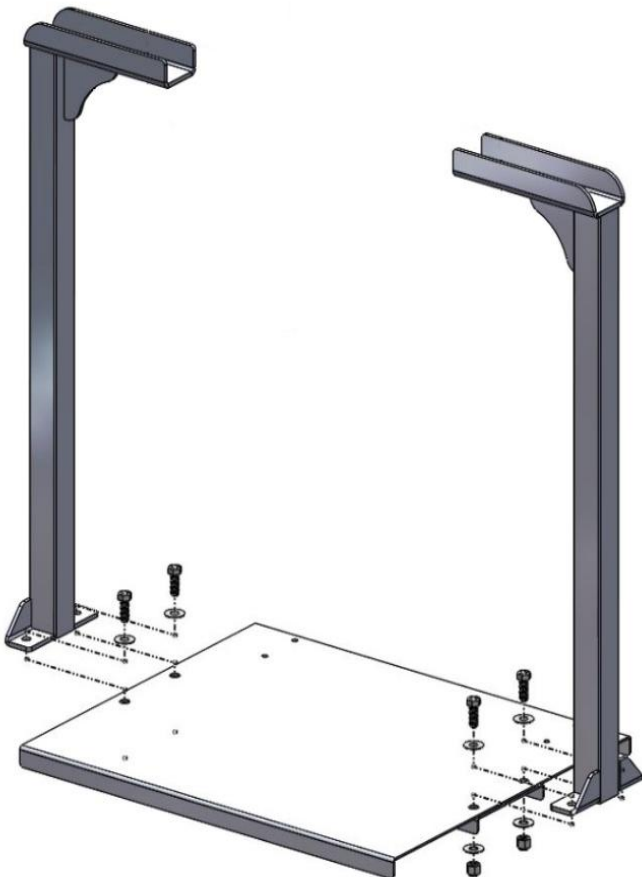

2. Mount the jack assembly on the bottom side of the uprights with (2) ½" x 1-½" long bolts, (4) ½" flat washers, and (2) ½" nylock nuts.

Note: The jack tongue plate is not shown, for viewing the left mounting bolt. The tongue plate comes assembled on the jack assembly.

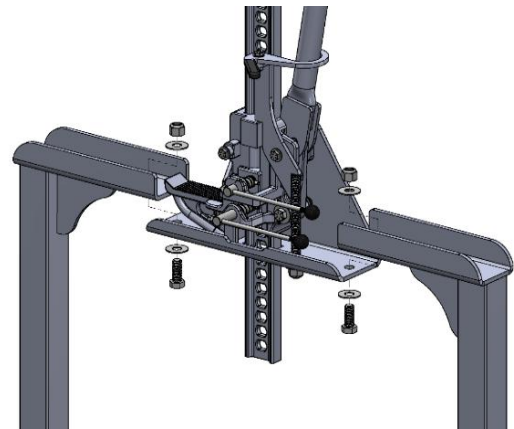

3. Align the uprights and jack assembly and then tighten all bolts.
4. Mount the ram plate to the jack assembly using (1) ½" x 2 ½" bolt and (1) ½" nylock nut.

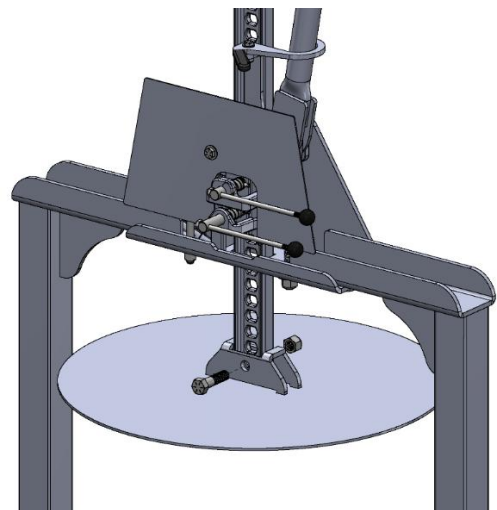

PackMaster™ Manual Compactor

OPERATION

1. Engage the handle lock hook as shown to hold the handle in the upright position when rotating levers.



4. Disengage the handle lock hook, and then pump the jack handle up and down to lower the ram plate for compaction.



2. To begin compacting waste, rotate the lower lever to the **down** position.



3. Then rotate the upper lever to the **down** position.



5. To retract the ram plate, apply and maintain downward pressure on the jack handle while first rotating the upper lever to the **up** position, and then the lower lever to the **up** position. Pump the jack handle up and down to raise the ram plate. Once the ram plate is raised to the desired position, engage the handle lock hook to hold the handle in the upright position.

Note: Downward pressure on the jack handle while rotating the levers to the **up** position removes the pressure on the jack pins, extending their life.



PackMaster™ Manual Compactor

PARTS LIST

Item	Description	Part Number	Item	Description	Part Number
1	Upright	10000988	10	Handle Socket	10001093
2	Base Plate	10004752	11	Jack Pin Spring	10001305
3	Jack Assembly	10001017	12	Pitman Pin	10001094
4	Ram Plate (20" Diameter)	10001428	13	Pitman Arm	10001095
Optional	Ram Plate (17" Diameter)	10001288	14	Handle Socket Bolt	10004921
5	Handle Lock Hook	10000774	15	Handle Socket Nut	10001286
6	Jack Support Stud	10000773	16	Roll Pin (For Jack Pins)	10001569
7	3-½" Jack Pin w/Lever (Upper)	10001567	17	Jack Face Plate	10000989
8	4-½" Jack Pin w/ Lever (Lower)	10001568	18	Jack Tongue Plate	10001016
9	Shear Pin w/ Nut	10001096	19	Jack Handle (Part of Jack)	N/A

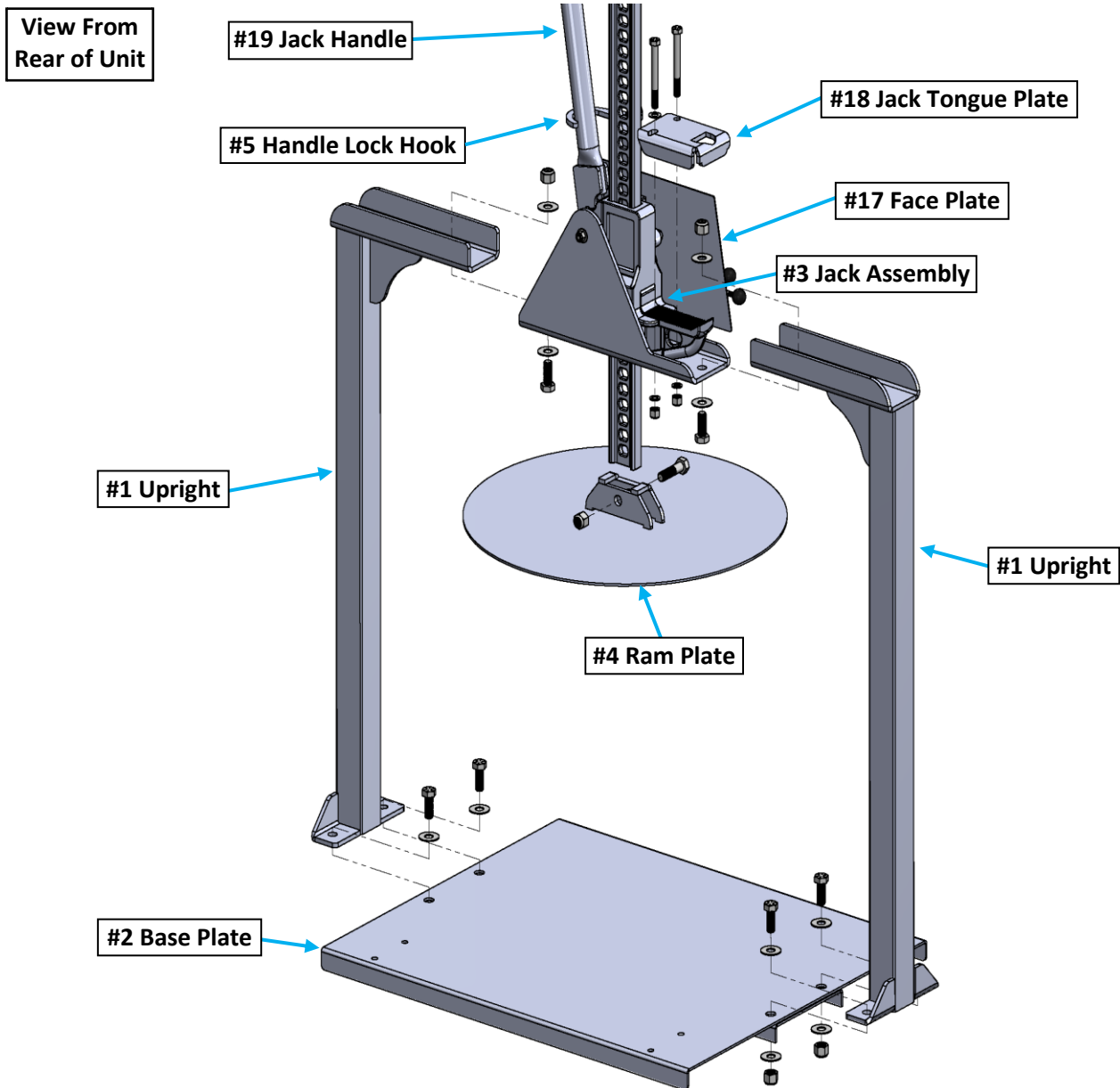

PackMaster™ Manual Compactor

View From
Front of Unit

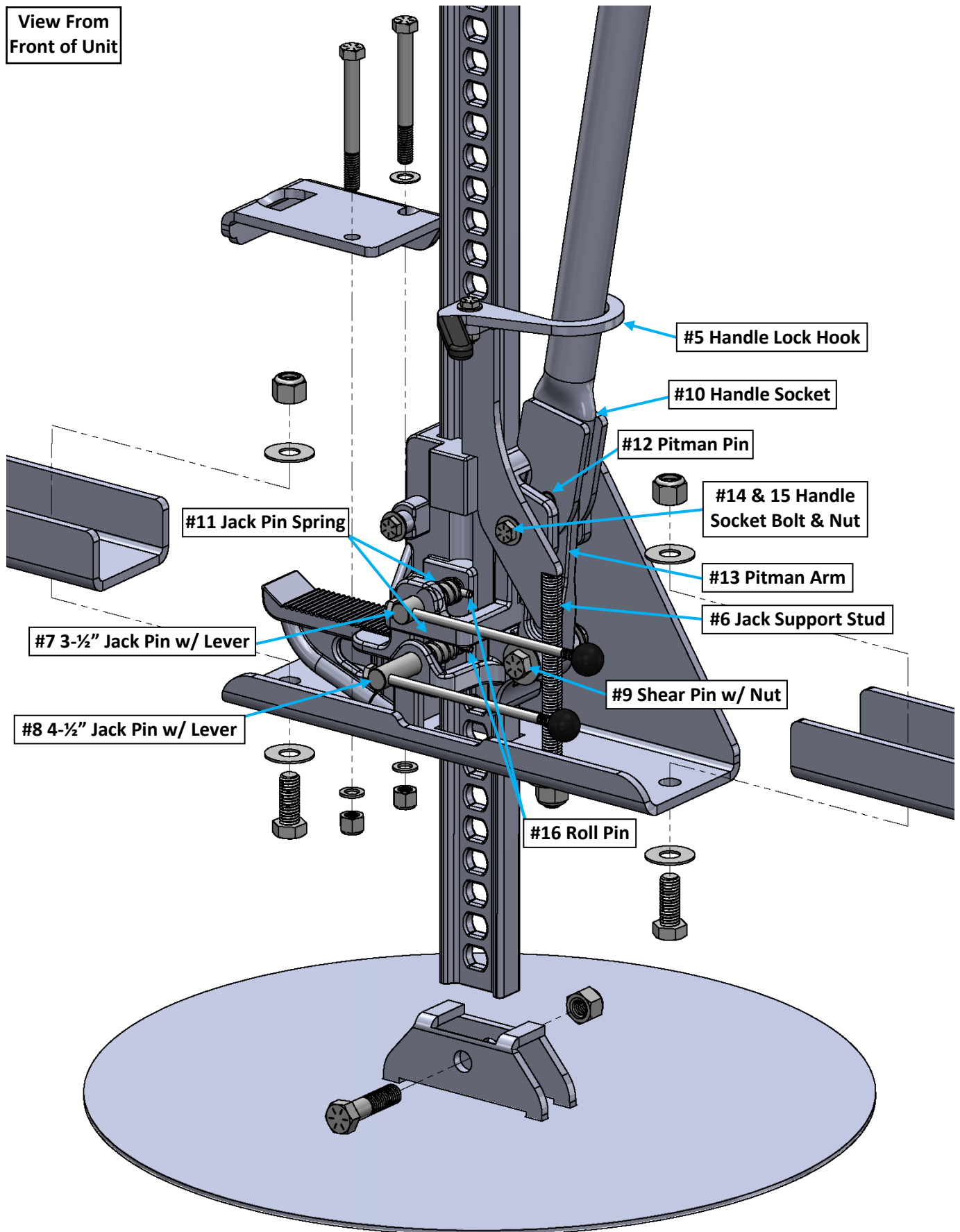

PackMaster™ Manual Compactor

10001258

18 Month Warranty

Newstripe, Inc. ("Newstripe") warrants to the original purchaser, for 18 (Eighteen) Months after date of purchase, that the equipment* hereby sold shall be free of defects in materials and workmanship. This warranty does not extend to any damage or malfunction resulting in misuse, neglect, accident, improper operation, or normal wear and tear.

* Gasoline engines, compressors, low pressure pumps, and transaxles are furnished with their respective manufacturers' warranties only and are not covered by any warranty of Newstripe. High pressure pumps manufactured by Newstripe (excluding wear items like diaphragms and valves) are warrantied for materials and workmanship for 12 Months after the date of purchase.

Damage incurred in shipment from Newstripe to the purchaser is the total responsibility of the shipping carrier. The purchaser is responsible for noting any damages on the Bill of Lading of the shipping carrier and Newstripe will work with the shipping carrier to resolve any damages incurred.

The Newstripe obligation under this warranty and any implied warranties is limited to replacement or repair of defective parts of its manufacture without charge for 18 (Eighteen) Months from date of purchase. For service under this warranty, the purchaser shall obtain an approved Return Materials Authorization (RMA) from Newstripe and then ship the defective part or parts of the equipment, transportation prepaid by the purchaser, to Newstripe together with a written description of any claimed defect and proof of purchase date of the materials being returned. To review Newstripe's complete guidelines for warranty claims and returns, please visit our website at www.newstripe.com.

The responsibilities described above are the only responsibilities of Newstripe under this written warranty or any implied warranty and may be exercised only within 18 (Eighteen) Months from the date of original purchase. In no event shall Newstripe be liable for incidental or consequential damages and no person has any authority to bind it to any representation or warranty. Newstripe is not responsible for work done, materials furnished, or repairs made by others without its specific written authorization.

This warranty shall be in lieu of any and all other warranties, expressed or implied, including any warranties of merchantability or fitness for a particular purpose, and there is no other representation or warranty of any kind with respect to the goods sold hereby except as set forth herein. It is expressly agreed that this warranty shall be limited to the adjustment, repair or replacement of parts and the labor and services required thereby. In no event, including any claim of negligence, shall Newstripe be liable for incidental or consequential damages.



Newstripe.com / 303-364-7786