



Product Manual

**EcoLiner™ SP
Self-Propelled Field Striping Machine
Honda Engine**

10005122



Proudly Made in the USA
Newstripe.com • 303-364-7786

5122.0426

EcoLiner™ SP Self-Propelled Field Striping Machine (Honda Engine)

TABLE OF CONTENTS

Precautionary Warning	Page 1
Assembly	Page 2-3
Operation	Page 4
Cleaning Procedure.....	Page 5
Cleaning Procedure..... (Winter Storage)	Page 5
Maintenance.....	Page 5
Spray Gun Assembly	Page 6
Parts List	Page 7
Troubleshooting Guide	Page 9-10
Warranty.....	Page 11

Thank you for purchasing the Newstripe EcoLiner™ SP Self-Propelled Field Striping Machine.

Please read over the instructions and make sure you understand the operating procedures before using the unit.

Please check the serial number on your unit. This Manual is for units with a Honda Engine and serial number 1037279 and above only. For units with serial numbers below 1037279, please contact Newstripe for the correct product manual.



EcoLiner™ SP Self-Propelled Field Striping Machine (Honda Engine)



PRECAUTIONARY WARNINGS

- **PLEASE** read and understand all operation instructions as detailed in this manual. Failure to follow specified instructions may result in equipment damage or severe injury to personnel.
- **DO NOT** use latex paints from hardware stores or home improvement centers in your machine. These types of paints have binders in them that will adhere to the internal parts of the pump, causing damage. You will not be able to clean these substances from the pump. You must use a good quality true water-based athletic field striping paint in your machine.
- **DO NOT** use solvent based paints in this machine. Use only good quality true water-based athletic field striping paint.
NOTE: Damage caused by use of the wrong paint is NOT COVERED UNDER WARRANTY!
- **ALWAYS** thin the paint in accordance with the manufacturer's recommendations prior to use. Most field-marking paints must be thinned before use with the EcoLiner. These paints are typically thinned at a minimum ratio of 1:1.
- **DO NOT** use paint that has not been thinned, as it will clog your machine.
- **ALWAYS** strain the paint before use. Field marking paint often has oversized material, lumps, and debris. If not properly strained, these contaminants will be drawn into the hoses, pump, and spray nozzle or spray gun where they may restrict paint flow.
- **NEVER** perform maintenance on the machine while the system is under pressure.
- **DO NOT** use solvents to clean the system. Solvents will damage internal components. Use only warm soapy water.
- **ALWAYS** consult your Facility Safety and/or Personnel Department for specified safety protocols prior to operating this equipment.

EcoLiner™ SP Self-Propelled Field Striping Machine (Honda Engine)

ASSEMBLY

1. Remove the unit from the box. Check for any damage that may have occurred during shipment. If you see any possible damage, make a note of it on the delivery paperwork and advise Newstripe immediately.
2. Set the handles behind the unit with the gun off to the right side. Attach the bottom of the handles to the back of the chassis with 5/16-18 x 1-1/2" hex head bolts, washers, and lock nuts. Hand tighten only at this time. (Pic 1)
3. Rotate the handle assembly upward and then rotate each handle brace (connected at the back axle) upward so that the holes in the braces line up with the upper holes in the handle assembly. Attach the top of the braces to the handles with 5/16-18 x 1-1/2" carriage bolts, and lock nuts. Tighten all bolts at this time. (Pic 1)

Pic 1



4. Remove the nut and washers from the stud on the drive lever on the left handle and then grease the stud. Attach the pre-adjusted drive control rod to the stud with a flat washer on either side of it. Tighten the nut so that the drive rod will rotate freely but have no side play. (Pic 2)

Pic 2



5. Remove the hairpin clip from the adjuster nut on the bottom of the drive rod. Grease the stud on the adjuster nut and then insert it in the hole in the arm of the drive unit from the outside. Replace the hairpin clip in the adjuster nut to secure it.

Note: The adjuster nut is pre-adjusted at the factory but may need to be slightly adjusted to provide adequate pressure on the tires to drive the unit. (Pic 3)

Pic 3



6. Place the throttle control lever on the engine to the idle position. Place the throttle cable control lever in the up position. Slide the throttle cable through the cable clamp on the engine between the air cleaner and fuel tank and the push the wire of the control cable through the clamp on the engine throttle control arm as shown below. Tighten the screw that secures the wire and then tighten the screw that secures the cable clamp against the cable sheath.

Note: You may remove the engine air cleaner if you need more room to access the cable clamps. (Pic 4)

Pic 4

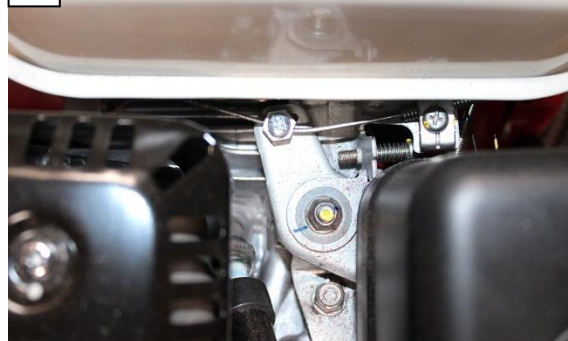

EcoLiner™ SP Self-Propelled Field Striping Machine (Honda Engine)

ASSEMBLY CONTINUED

1. Set the pail on the machine as shown below with the return hoses from the handle inside. Connect the lower pump outlet hose to the fitting at the bottom of the pressure valve on the handle and then tighten it with an adjustable wrench. (Pic 5)
2. Remove the black cap from the top inlet fitting of the pump. Place the filter end of the suction hose into the pail and then connect the other end to the top fitting of the pump, hand tight only. (Pic 5)
3. Connect the spray hose to the elbow fitting that points forward on the right side of the handle and then tighten it with an adjustable wrench. Hang the coil of hose on the fitting assembly. (Pic 5)



4. Unpack the spray gun support tube, spray gun mounting bracket, and spray shields.
5. Slide the gun support tube with shields into the receiver tube on the front of the machine and then hand tighten the star knobs. (Pic 6)

6. Slide the spray gun mounting bracket onto the upright of the gun support tube and then hand tighten star knob. (Pic 6)
7. Place the spray gun (without the hose attached) in the gun mount and secure it with the gun mount star knob. (Pic 6)
8. Connect the other end of the spray hose to the spray gun and then tighten it with an adjustable wrench.

NOTE: The line width is adjusted by raising or lowering the spray gun and also by selecting the appropriate spray nozzle.

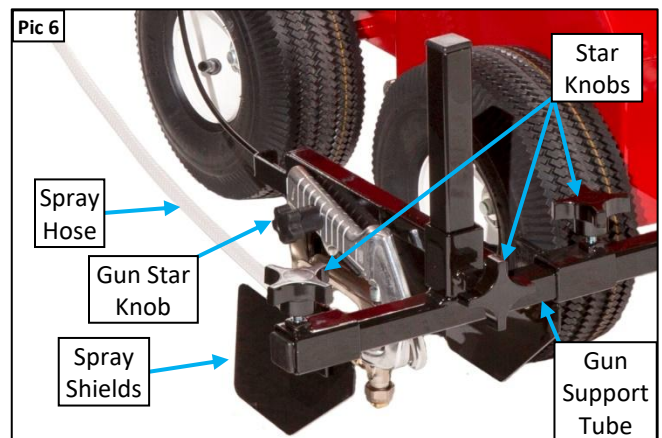

9. **This unit is shipped without oil.** Fill the engine with 18oz of SAE 5W-30 Full Synthetic Motor Oil before starting. Always check the oil level in the engine before starting.

EcoLiner™ SP Self-Propelled Field Striping Machine (Honda Engine)

OPERATION

1. Adjust the spray shields to a 4" width. You may have to raise or lower the spray gun so that the machine will produce a 4" line. To stripe narrower or wider lines, select the proper spray nozzle from the application description table on page 5. Adjust the spray shields for the line width desired and then adjust the spray gun up or down as needed to produce the desired line width.
2. Move the pump engagement lever to the "OFF" position, toward the rear of the machine.
3. Disengage the self-propelled drive mechanism by pulling the lever back toward the rear of the machine.
4. Add water (for testing, practicing, or cleaning) or pre-thinned and strained paint to the pail.
5. On the engine, move the On/Off fuel lever to the "On" position. Move the choke lever to the "choke" position. Move the throttle lever to about the $\frac{3}{4}$ position. Turn the On/Off switch to the "On" position. Pull the starter cord. Once the engine begins to run, move the choke lever to the run position. Adjust the throttle slightly to where the engine runs the smoothest.
6. Move the pump engagement lever to the forward "ON" position. The lever should now be in a horizontal position.
7. Open the pump prime valve next to the pressure valve. Lift the lid slightly on the pail and watch the paint flow from the return hose. Once there is a continuous flow from the hose, close the pump prime valve. The unit should now spray when the lever on the handle is squeezed.
8. To engage the self-propelled mechanism, simply push the drive lever to the forward most position. Pull the drive lever back to stop. The speed is controlled by adjusting the engine speed.



OPERATIONAL NOTES

- **ADJUST** the side spray shields for line width and then adjust the spray gun height up or down as needed to achieve the desired line width.
- **NOTE:** water will produce a wider line than paint.
- **ALWAYS** thin the paint in accordance with the manufacturer's recommendations prior to use. Most field-marking paints must be thinned before use with the EcoLiner. These paints are typically thinned at a minimum ratio of 1:1.
- **ALWAYS** strain the paint before use. Field marking paint often has oversized material, lumps, and debris. If not properly strained, these contaminants will be drawn into the hoses, pump, and spray nozzle or spray gun where they may restrict paint flow.
- **ALWAYS** prime the pump before each use and when you run the pail dry. If you need to reduce the spray pressure, unscrew the pressure valve cap until it is where you would like it, and then run the locking ring up against the cap to maintain the pressure setting.
- **ALWAYS** disengage the pump lever when the paint pail becomes empty. Continuing to run the pump when paint has run out will dry paint inside the pump.

EcoLiner™ SP Self-Propelled Field Striping Machine (Honda Engine)

CLEANING PROCEDURE

1. When your striping job is complete, pull the paint return hose & prime valve hose out of the lid and point them toward the ground behind the machine or into a separate pail.
2. Remove the paint pail lid, wipe it off, and set it aside. Pull out the suction hose and wipe or rinse it off and then place it in a clean container of water.
3. Remove the nozzle cap, nozzle, and valve seat from the gun and put them in a container of soapy water to soak.
4. Remove the pail of unused paint from the machine and cover it for use the next time you stripe.
5. Place an empty pail on the machine and add two gallons of clean soapy water. Place the suction hose in the pail on the machine but leave the return and pump prime hoses out of the pail. This allows you to flush all of the hoses of paint.
6. Clean the spray gun parts that have been soaking and then reassemble them onto the spray gun.
NOTE: The cone shaped depression in the gun seat goes toward the spray nozzle.
7. Start the engine and then use the pump prime valve to prime the pump. Activate the spray gun until the spray runs clear with water.
CAUTION: The return hoses will “jump” from the fluid pressure when cycling the prime valve.
8. Clean and rinse the exterior of the machine with warm soapy water. **Pressure washing is not recommended.**
9. Use soapy water at least once a week to thoroughly clean the pump. Add soap (dish washing detergent) to 2-3 gallons of water and then run the machine and let it circulate back to the pail as long as desired. Once you have completed this, empty the pail.

CLEANING PROCEDURE FOR WINTER (FREEZING) STORAGE

1. Clean as instructed in the normal cleaning procedure.
2. Remove as much gas from the engine fuel tank as you can. Run the engine until it runs out of gas.
3. Disconnect the paint hoses from the pump and gun and then drain the hoses.
4. Remove the screen from the suction hose and hold the end up. Pour a little Newstripe Pump Defender into the hose. Pull the cord on the engine to draw the Pump Defender into the pump. The unit may now be stored in freezing temperatures.
5. Drain and change the engine oil in the spring before adding fuel to the tank for the first use.

MAINTENANCE

ITEM	CHECK	MAINTENANCE ACTION
Engine Oil Full Synthetic SAE 5W-30	Prior to every use	Change the engine oil after the first 20 hours of operation and then every 100 hours thereafter.
Paint System	After every use	Clean the paint pail, hoses, and gun.
Hoses and Pump	After every use	Run soapy water through the pump and hoses for additional cleaning.
Wheels and Tires	Check the air pressure before each use.	Fill the tires with air as needed. Grease the wheels monthly.
Handles	Monthly	Check the handle bolts for tightness to the chassis and handle braces.
Engine Air Filter	Monthly	Replace every 4 months

EcoLiner™ SP Self-Propelled Field Striping Machine (Honda Engine)

SPRAY GUN ASSEMBLY (10001949)

Item	Description	Part Number
#43	Low Pressure Spray Gun	10000147
#44	Valve Seat	10000136
#45	8004 Nozzle Included	N/A
#46	Nozzle Cap (4-Pack)	10001890

Nozzle (4-Pack)	Application Description	Part Number
5002	2" - 3" Lines	10001891
8002	4" - 5" Lines (Short Turf)	10001892
8004	4" - 5" Lines	10001893
8005	4" - 5" Lines (Heavy Turf)	10003493
9505	5" - 6" Lines	10001894

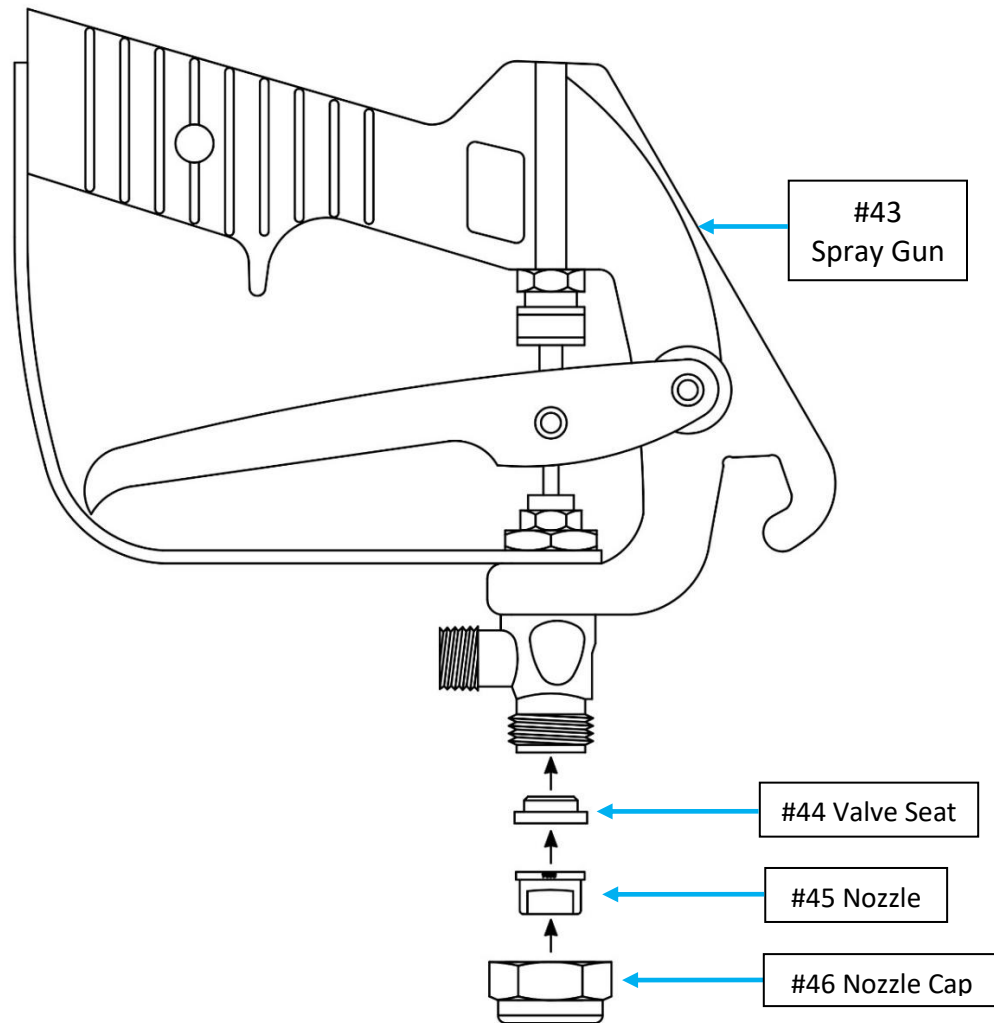

ENGINE LUBRICANT AND PARTS

ITEM	SPECIFICATIONS
Engine	Part Number 10000371, Honda GX120 With Oil Alert
Oil Capacity	18 Ounces (0.56 Liters) Full Synthetic 5W-30
Spark Plug	NGK Part Number BPR6ES or Denso Part Number W20EPR-U
Air Filter	Part Number 10000401

EcoLiner™ SP Self-Propelled Field Striping Machine (Honda Engine)

PARTS LIST

Item	Description	Part Number	Item	Description	Part Number
1	Chassis	10004610	28	Hose Assembly, Pump Pressure	10004469
2	Engine, Honda GX120	10000371	29	½" Male Brass Tee Fitting	10004111
3	Engine Air Filter Element (Not Shown)	10000401	30	½" to ¼" Brass Reducer Fitting	10002481
4	Wheel Assembly (4)	10000012	31	Pump Prime Valve	10000233
5	Handle Bars	10002023	32	¼" Brass 90 Deg. Male Elbow Fitting	10000159
6	Handle Support Braces (2)	10004612	33	¼" Female Brass Cross Fitting	10000235
7	Control Cable	10002518	34	¼" Brass 90 Deg. Street Elbow Fitting	10004131
8	Control Lever	10002951	35	¼" Brass Plug Fitting	10000113
9	Throttle Cable	10000696	36	¼" Brass Ball Seat Hex Nipple Fitting	10000731
10	Drive Lever	10002072	37	Pump Engage Lever	10001817
11	Drive Control Rod	10004603	38	Belt Guard	10002030
12	Hose Assembly, Paint	10000695	39	3/8" MPT x MGHT 90 Deg. Fitting	10004459
13	Hose Assembly, Suction	10004470	40	Pump Assembly	10003367
14	Filter Screen, Suction Hose (Not Shown)	10002842	41	Drive Assembly	10002088
15	Hose Assembly, Return (2)	10003692	42	Drive Rollers (2)	10003387
16	Spray Gun Mount	10004651	43	Gun Mount Star Knob	10004480
17	Spray Gun Assembly	10001949	44	Belt, Drive (A26)	10001757
18	Spray Gun Support Arm	10003550	45	Belt, Pump Drive (3L260)	10001755
19	Pivot Assembly with Shield, Right	10004825	46	Pulley, Pump Belt Idler	10001111
20	Pivot Assembly with Shield, Left	10004824	47	Pulley, Drive Belt Idler	10001111
21	Star Knob, Common (5)	10000007	48	Pulley, Drive	10001115
22	Cable Adjuster with Nut	10000018	49	Pulley, Engine	10001739
23	Cable Swivel Stop	10001577	50	Pulley, Pump (Not Shown)	10003368
24	Pressure Valve Adjusting Cap (Part Of Valve)	N/A	51	Spring, Pump Belt Tensioner	10000649
25	Locking Ring (Part Of Valve)	N/A	52	Spring, Idler Arm	10000692
26	Pressure Limiter Collar (Part Of Valve)	N/A	53	Bearing, Pump Shaft (2)	10003131
27	Pressure Valve	10003478	54	Pump Shaft	10003365

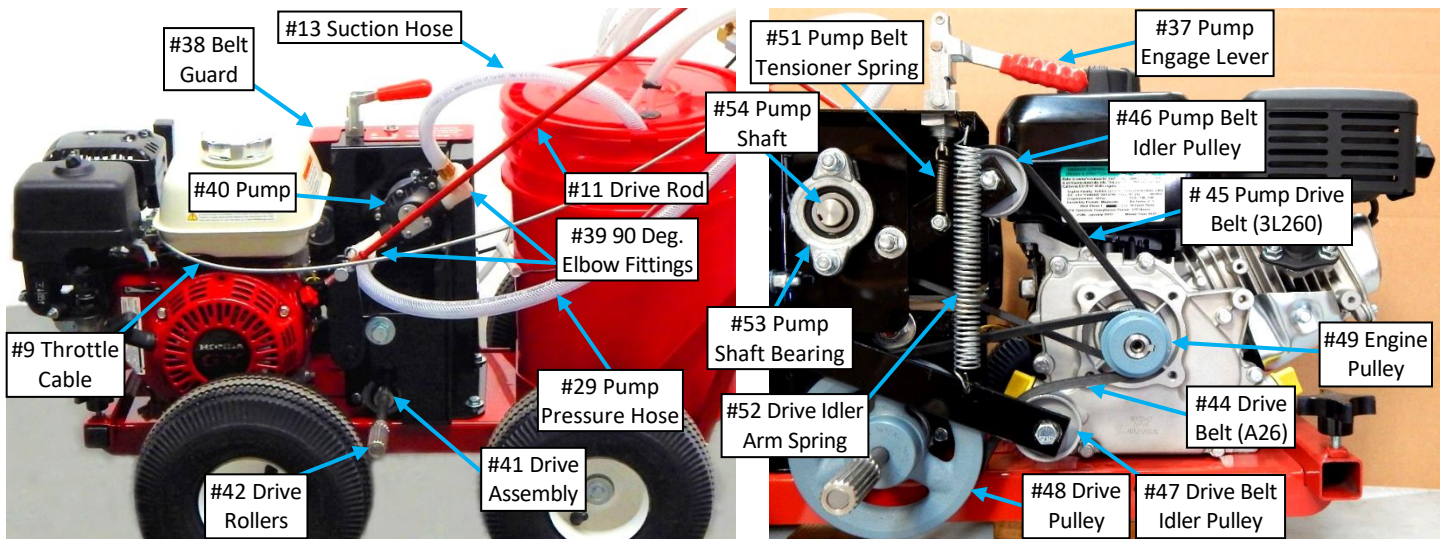

EcoLiner™ SP Self-Propelled Field Striping Machine (Honda Engine)

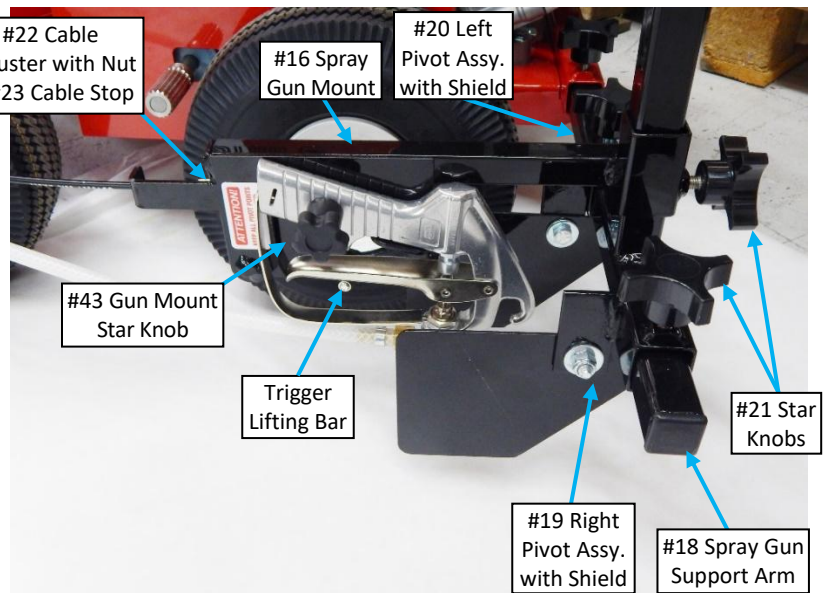
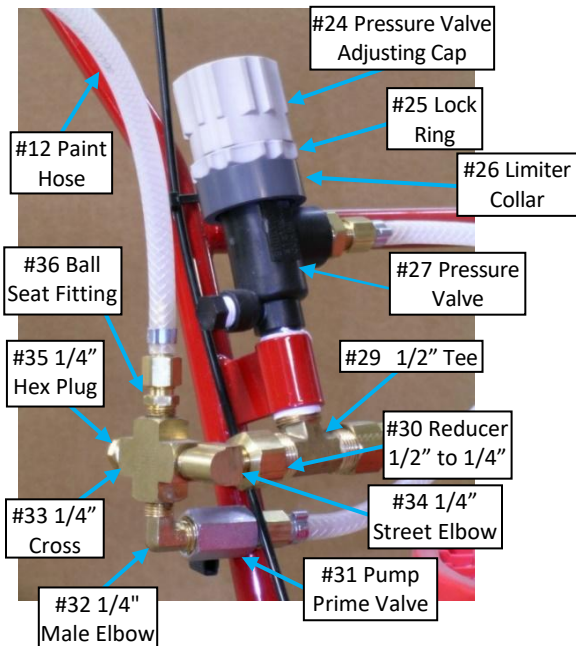

EcoLiner™ SP Self-Propelled Field Striping Machine (Honda Engine)

TROUBLESHOOTING GUIDE

PROBLEM	POSSIBLE CAUSE	REMEDY
The pump will not prime.	There is air in the spray system.	Open the pump prime valve and check for flow from the return hose into pail. When the flow is continuous, close the valve.
The pump will not prime after relieving the air in the system.	The pump or hoses may be restricted.	Disconnect the supply and discharge hoses and clean them. Pour hot soapy water into the inlet of the pump and let it soak. Reconnect the hoses and restart the pump.
The pump still will not prime.	The spray system was not thoroughly cleaned after the previous use.	Pour more hot soapy water into the inlet of the pump. Jog the pump by pulling the starter cord several times with engine off to get the soap into the pump. Let it soak 15-30 minutes and then try pumping water. If the pump starts pumping water, let it circulate the water for 5-10 minutes before adding paint. The pump does not need to be rinsed of the soap, as it will mix easily with the paint. If the pump still will not prime, call Newstripe for assistance. Disassembly of the pump will void the warranty.
The pump will not run.	The drive belt is loose or broken.	Inspect, and then adjust or replace the belt. The belt should deflect approximately ½" between pulleys.
The paint is leaving the nozzle in a stream, and not a spray pattern.	The paint is too thick	Thin the paint.
The pressure too low.	The pressure valve needs adjusted.	Loosen the locking ring. Turn the pressure valve cap clockwise to increase the pressure and then run the locking ring up against the cap to maintain the pressure setting. Do not remove the locking ring.
The spray stream is inconsistent.	The nozzle screen is obstructed. The suction hose screen is clogged or obstructed.	Remove the nozzle screen and clean or replace it. Remove suction hose and screen. Filter the paint, clean the screen, and remove any clogs.
The spray pattern is too narrow or is uneven.	The spray gun height is incorrect. The nozzle may be the wrong size, or misaligned. The paint viscosity may be too thick.	Adjust the spray gun height up or down to achieve the desired line width. See the Nozzle Assembly Guide. The nozzle slot must be at 90 degrees to the direction of travel. Thin the paint in accordance with the manufacturer's recommendations.

EcoLiner™ SP Self-Propelled Field Striping Machine (Honda Engine)

TROUBLESHOOTING GUIDE CONTINUED

PROBLEM	POSSIBLE CAUSE	REMEDY
Paint drips from the gun nozzle after releasing the lever.	<p>The control cable is out of adjustment.</p> <p>The valve seat in the spray gun is dirty or worn.</p> <p>The gun is not in the mount correctly.</p> <p>Faulty control lever.</p> <p>The gun mount pivot points or the spray control lever needs lubrication.</p>	<p>Check the cable at the spray gun mount. Adjust the cable as needed or replace it if it is damaged.</p> <p>Disassemble the gun and clean or replace the valve seat.</p> <p>Adjust the gun position so that the trigger lifting bar allows spray trigger to release completely.</p> <p>Replace the lever if it is worn or damaged.</p> <p>Keep all gun mount pivot points, the spray control lever, and pump engage lever lubricated with spray oil containing PTFE, such as Slick 50 One Lube.</p>
The drive rollers are turning but the unit will not move when the drive is engaged.	<p>The drive control rod is out of adjustment.</p>	<p>Remove the hairpin clip that holds the adjustment nut in the drive unit arm. Loosen the adjustment nut jam nut. Turn the adjustment nut clockwise a couple turns and then reassemble it in the drive unit arm in reverse order. Make sure that both tires are inflated equally for proper engagement.</p>
The drive rollers are not turning.	<p>The drive belt or the drive belt tensioner spring may be broken.</p>	<p>Replace the drive belt or the drive belt tensioner spring as needed.</p>

Your machine is designed to be simple and safe to operate.

Please call Newstripe at 303-364-7786 if you have any questions during setup, painting, or cleaning.

EcoLiner™ SP Self-Propelled Field Striping Machine (Honda Engine)

10005122

24 Month Warranty

Newstripe, Inc. ("Newstripe") warrants to the original purchaser, for 24 (Twenty Four) Months after date of purchase, that the equipment* hereby sold shall be free of defects in materials and workmanship. This warranty does not extend to any damage or malfunction resulting in misuse, neglect, accident, improper operation, or normal wear and tear.

* Gasoline engines, compressors, low pressure pumps, and transaxles are furnished with their respective manufacturers' warranties only and are not covered by any warranty of Newstripe. High pressure pumps manufactured by Newstripe (excluding wear items like diaphragms and valves) are warranted for materials and workmanship for 12 Months after the date of purchase.

Damage incurred in shipment from Newstripe to the purchaser is the total responsibility of the shipping carrier. The purchaser is responsible for noting any damages on the Bill of Lading of the shipping carrier and Newstripe will work with the shipping carrier to resolve any damages incurred.

The Newstripe obligation under this warranty and any implied warranties is limited to replacement or repair of defective parts of its manufacture without charge for 24 (Twenty Four) Months from date of purchase. For service under this warranty, the purchaser shall obtain an approved Return Materials Authorization (RMA) from Newstripe and then ship the defective part or parts of the equipment, transportation prepaid by the purchaser, to Newstripe together with a written description of any claimed defect and proof of purchase date of the materials being returned. To review Newstripe's complete guidelines for warranty claims and returns, please visit our website at www.newstripe.com.

The responsibilities described above are the only responsibilities of Newstripe under this written warranty or any implied warranty and may be exercised only within 24 (Twenty Four) Months from the date of original purchase. In no event shall Newstripe be liable for incidental or consequential damages and no person had any authority to bind it to any representation or warranty. Newstripe is not responsible for work done, materials furnished, or repairs made by others without its specific written authorization.

This warranty shall be in lieu of any and all other warranties, expressed or implied, including any warranties of merchantability or fitness for a particular purpose, and there is no other representation or warranty of any kind with respect to the goods sold hereby except as set forth herein. It is expressly agreed that this warranty shall be limited to the adjustment, repair or replacement of parts and the labor and services required thereby. In no event, including any claim of negligence, shall Newstripe be liable for incidental or consequential damages.



Newstripe.com / 303-364-7786